

TRIANGLE PLATES; HIGH TENSILE PLATES

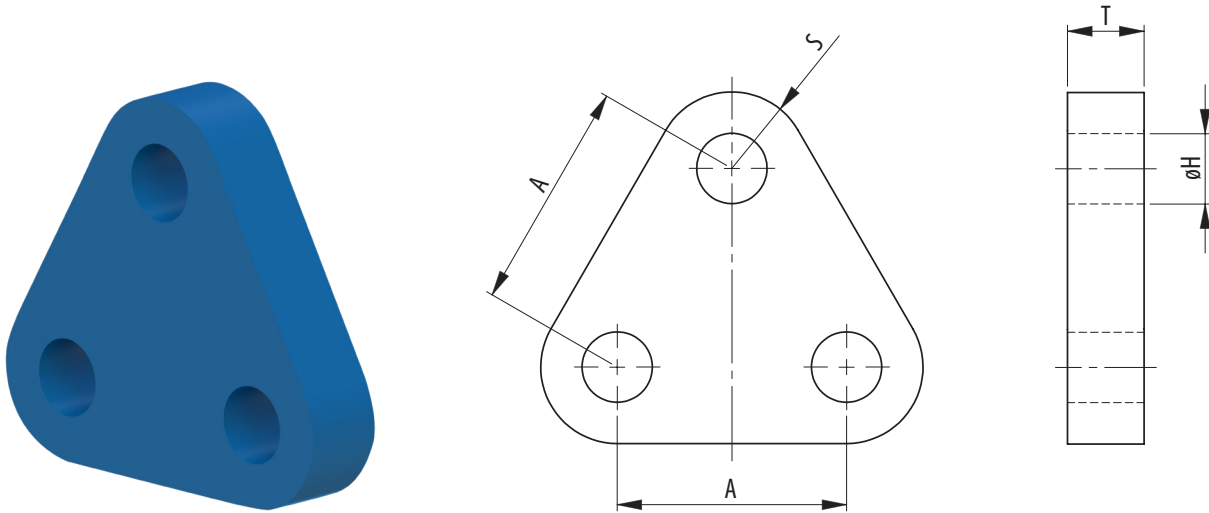

Model No.	WLL (UStons)	MBL (UStons)	Dimensions (inch)				Weight (lbs)
			A	øH	T	S	
TP 40.35.9,5	10.5	52.4	3.94	1.38	1.57	1.38	11
TP 40.40.12	13.2	66.1	4.33	1.57	1.57	1.57	14
TP 45.42.13,5	14.9	74.4	4.72	1.65	1.77	1.67	18
TP 45.45.17	18.7	93.7	5.12	1.77	1.77	1.97	24
TP 50.55.25	27.6	137.8	5.51	2.17	1.97	2.56	37
TP 60.60.35	38.6	192.9	5.91	2.36	2.36	2.76	51
TP 80.75.55	60	303.1	7.09	2.95	3.15	3.35	97
TP 90.90.85	93	468.5	8.66	3.54	3.54	4.33	175
TP 110.105.120	132	661.4	9.45	4.13	4.33	5.12	280
TP 130.115.150	165	826.7	10.24	4.53	5.12	5.31	360
TP 140.115.175	192	964.5	11.42	4.53	5.51	5.71	480
TP 150.140.200	220	1102.3	14.96	5.51	5.91	6.30	725
TP 170.150.250	275	1377.9	17.72	5.91	6.69	6.89	1080
TP 170.160.300	330	1653.5	15.75	6.30	6.69	9.06	1325
TP 200.180.400	440	2204.6	18.90	7.09	7.87	10.24	2125
TP 200.200.500	550	2755.8	19.69	7.87	7.87	12.20	2720
TP 250.220.600	660	3306.9	21.65	8.66	9.84	12.20	3615
TP 250.230.700	770	3858.1	22.83	9.06	9.84	13.39	4250
TP 250.235.800	880	4409.2	23.23	9.25	9.84	14.96	4965
TP 280.245.900	990	4960.4	24.41	9.65	11.02	16.14	6415
TP 300.255.1000	1100	5511.6	25.59	10.04	11.81	16.93	7570
TP 320.285.1250	1375	6889.4	28.74	11.22	12.60	19.29	10400
TP 320.305.1500	1650	8267.3	30.71	12.01	12.60	22.44	13370

Minimum Ultimate Strength = 5 x WLL

- Other sizes possible.
- Painted blue (RAL 5017).
- Material certificate according EN 10204 3.1 included.

 SEE OUR WARNING & SAFETY INFORMATION ON PAGES 136 - 148

