

**TAILGRIP OPEN WEDGE UTILITY SOCKET WITH PIN**

**QUENCHED AND TEMPERED CAST STEEL**

**NEW**

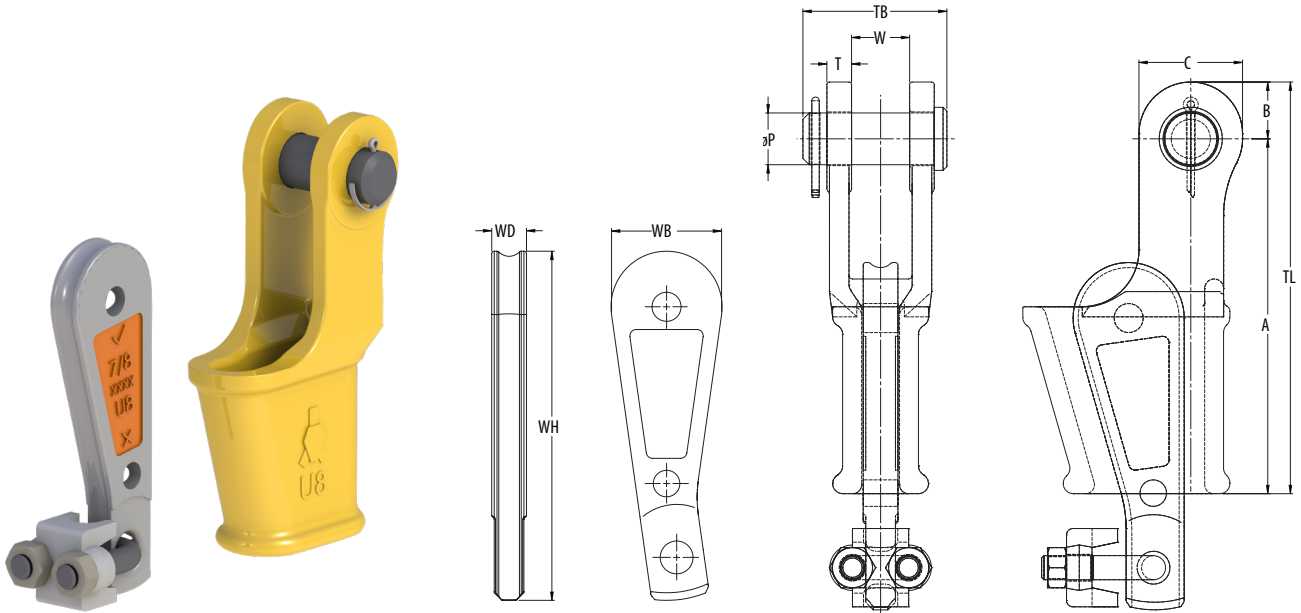

Model No.	MBL (Mtons)	for wire ø (inch)	Dimensions (inch)											Weight (lbs)
			A	B	C	øP	T	TL	TB	W	WH	WB	WD	
OWS-U 4.10 P	12	3/8	146	27	49	25	13	173	64	25	152	49	11	2,1
OWS-U 4.11 P	12	7/16	146	27	49	25	13	173	64	25	167	45	13	2,1
OWS-U 4.13 P	12	1/2	146	27	49	25	13	173	64	25	169	45	13	2,1
OWS-U 5.13 P	20	1/2	195	38	76	32	16	233	83	36	199	49	19	3,9
OWS-U 5.14 P	20	9/16	195	38	76	32	16	233	83	36	192	51	18	3,9
OWS-U 5.16 P	20	5/8	195	38	76	32	16	233	83	36	194	51	18	3,9
OWS-U 6.16 P *	35	5/8	215	38	76	32	15	253	95	38	195	60	21	6,1
OWS-U 6.19 P *	35	3/4	215	38	76	32	15	253	95	38	195	60	21	5,9
OWS-U 7-22 P	60	7/8	245	41	83	32	17	286	83	33	269	54	27	7,5
OWS-U 7-25 P	60	1	245	41	83	32	17	286	83	33	269	48	27	7,5
OWS-U 8A.16 P	35	5/8	228	39	73	41	20	267	114	46	225	75	21	8,5
OWS-U 8A.19 P	35	3/4	228	39	73	41	20	267	114	46	225	75	21	8,3
OWS-U 8.22 P *	60	7/8	281	45	82	41	20	326	114	46	277	88	28	13
OWS-U 8.26 P *	60	1	281	45	82	41	20	326	114	46	274	83	28	13
OWS-U 10.28 P *	90	1 1/8	349	56	110	41	23	405	120	46	351	112	33	24
OWS-U 10.32 P *	90	1 1/4	349	56	110	41	23	405	120	46	349	108	33	24
OWS-U 11.28 P	90	1 1/8	356	59	114	64	27	415	156	67	362	121	28	27
OWS-U 11.32 P	90	1 1/4	356	59	114	64	27	415	156	67	386	117	30	29

\* EXPECTED AVAILABILITY EARLY 2023

MBL = Minimum Breaking Load

- The standard finish of the sockets is ISO 12944 C3M RAL 1023.
- All sockets are provided with an EN 10204-2.1 declaration of conformity and EN 10204-3.1 material certificate.
- Dimensional tolerances are ±5% for the jaw opening (W) and pin diameter (øP).
- For other dimensional tolerances please contact Ropeblock.
- Surface finish e.g. hot dip galvanizing or paint may add to the overall thickness and fork distance.
- The wedges are colored for easy rope size identification.  
 Orange : Smallest wire rope size  
 Black : Intermediate wire rope size  
 Blue : Largest wire rope size
- Only use Ropeblock Utility wedges in combination with Ropeblock Utility wedge sockets.

**SEE OUR WARNING & SAFETY INFORMATION ON PAGES 136 - 149**

