

TAILGRIP OPEN WEDGE SOCKETS WITH PIN

QUENCHED AND
TEMPERED CAST STEEL

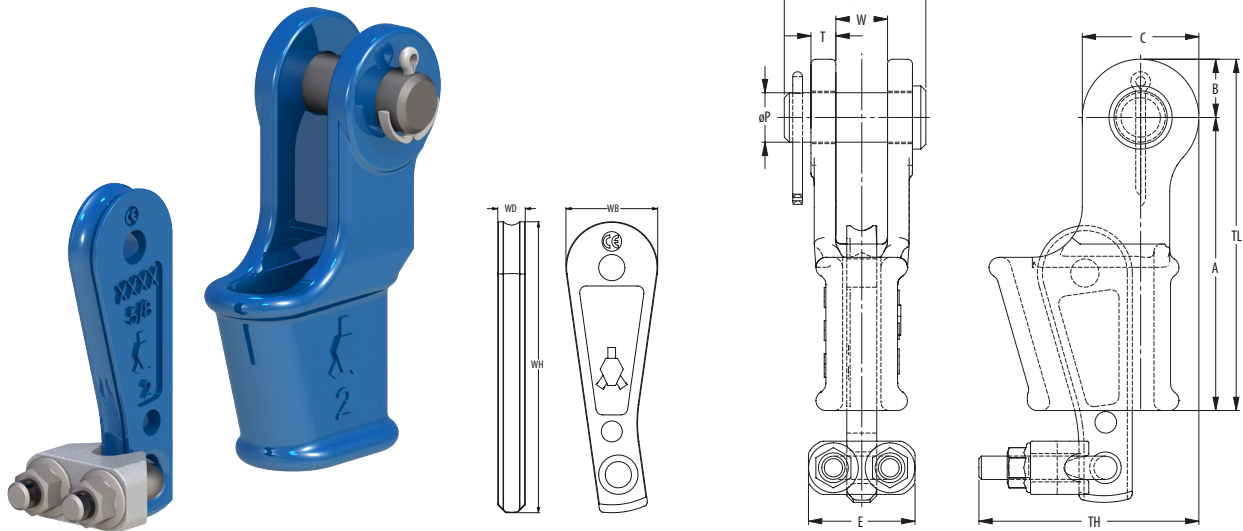

Model No.	MBL (UStons)	for wire ø		Dimensions (inch)													Weight (lbs)
		(mm)	(inch)	A	B	C	E	øP	T	TH	TL	TB	W	WH	WB	WD	
OWS-TG 0.5 P	13	9-10	3/8	5.71	0.91	1.81	1.57	0.81	0.43	2.99	6.61	2.48	0.81	5.12	1.42	0.47	4
OWS-TG 1 P	22	11-13	1/2	5.75	1.12	2.24	2.17	0.98	0.47	3.94	6.87	2.64	0.98	6.69	1.89	0.55	5
OWS-TG 2 P	28	14-16	5/8	6.93	1.38	2.76	2.52	1.18	0.59	4.92	8.31	3.35	1.22	7.66	2.24	0.71	9
OWS-TG 3 P	44	18-19	3/4	8.27	1.57	3.15	2.68	1.38	0.63	5.59	9.84	3.74	1.50	8.74	2.76	0.83	15
OWS-TG 4 P	61	20-22	7/8	9.35	1.87	3.74	2.91	1.61	0.71	6.46	11.22	4.33	1.73	9.86	3.03	0.94	22
OWS-TG 5 P	83	23-26	1	10.83	2.17	4.33	3.31	2.01	0.87	7.44	12.99	5.04	2.01	10.79	3.27	1.08	33
OWS-TG 6 P	99	27-29	1 1/8	12.20	2.56	5.12	3.74	2.24	0.98	8.54	14.76	5.59	2.24	11.48	3.58	1.18	46
OWS-TG 7 P	121	30-32	1 1/4	13.78	2.87	5.75	4.13	2.48	1.10	9.37	16.65	6.10	2.48	13.74	4.25	1.30	68

MBL = Minimum Breaking Load

- The standard finish of the sockets is blue primer coating and hot dipped galvanized (OWS 0,5 only galvanized)
- All sockets are provided with an EN 10204-2.1 declaration of conformity and EN 10204-3.1 material certificate.
- Dimensional tolerances are ±5% for the jaw opening (W) and pin diameter (øP).
- For other dimensional tolerances please contact Ropeblock.
- Surface finish e.g. hot dip galvanizing or paint may add to the overall thickness and fork distance.

SEE OUR WARNING & SAFETY INFORMATION ON PAGES 136 - 149

