

SUPER REEVE CONNECTOR SWIVEL SOCKETS WITH BOLT AND NUT

**QUENCHED AND
TEMPERED CAST STEEL**

SOCKETS

PATENTED

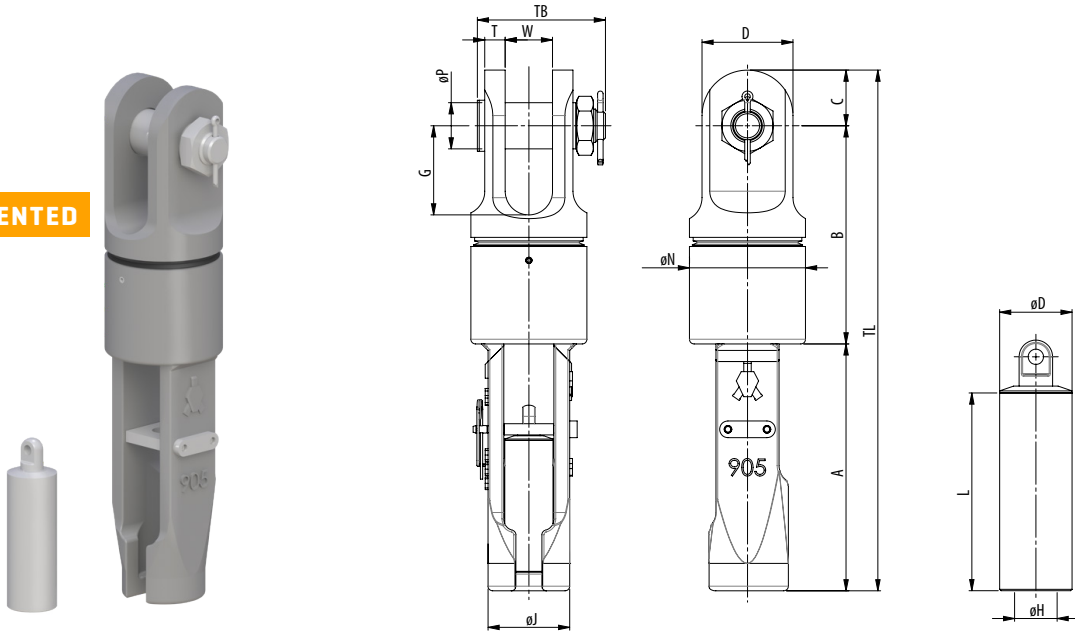

Model No.	MBL (UStons)	for wire ø		Dimensions (inch)															Weight (lbs)
		(mm)	(inch)	A	B	C	øH	øP	T	W	G	D	øD	øJ	øN	L	TB	TL	
SCS-SW 902 B	28	13-16	½ - ⅝	7.17	6.18	1.26	0.75	1.18	0.55	1.26	2.36	2.28	1.26	2.20	2.99	3.86	3.78	14.61	15
SCS-SW 903 B	44	16-19	⅝ - ¾	8.19	7.32	1.57	0.87	1.38	0.63	1.50	2.76	2.76	1.57	2.56	3.66	4.49	4.21	17.09	24
SCS-SW 904 B	61	20-22	⅞	9.37	8.19	1.77	1.00	1.61	0.75	1.73	3.15	3.15	1.73	3.03	4.13	5.12	4.84	19.33	37
SCS-SW 905 B	83	23-26	1	10.47	9.25	2.36	1.20	1.97	0.87	2.01	3.78	3.86	2.05	3.46	4.92	5.59	5.43	22.09	57
SCS-SW 906 B	99	27-29	1⅛	11.42	10.31	2.56	1.34	2.24	0.98	2.24	4.21	4.25	2.28	3.78	5.31	6.26	6.30	24.29	75
SCS-SW 907 B	138	30-32	1¼	12.87	11.50	2.87	1.43	2.48	1.10	2.48	4.65	4.72	2.52	4.33	5.91	6.97	6.50	27.24	108

MBL = Minimum Breaking Load

- The standard finish of the sockets is blue primer coating and hot dipped galvanized.
- All sockets are provided with an EN 10204-2.1 declaration of conformity and EN 10204-3.1 material certificate.
- Dimensional tolerances are ±5% for the jaw opening (W) and pin diameter (øP).
- For other dimensional tolerances please contact Ropeblock.
- Surface finish e.g. hot dip galvanizing or paint may add to the overall thickness and fork distance.

