

SUPER REEVE CONNECTOR SOCKETS WITH PIN

QUENCHED AND TEMPERED CAST STEEL

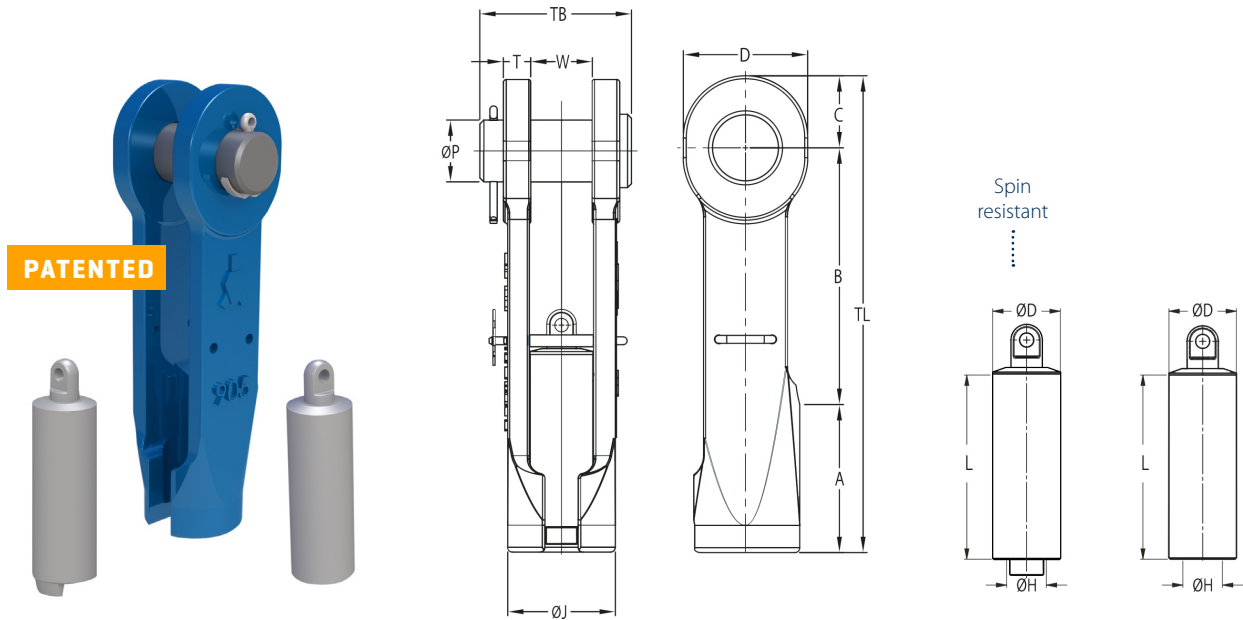

Model No.	MBL (UStons)	for wire ø		Dimensions (inch)													Weight (lbs)	
		(mm)	(inch)	A	B	C	øH	øP	T	W	D	øD	øJ	L	TB	TL		
SCS 901 P	22	11-13	7/16 - 1/2	-	-	-	-	-	-	-	-	-	-	-	-	-	-	-
SCS 902 P	28	13-16	1/2 - 5/8	3.35	5.24	1.26	0.75	1.18	0.55	1.26	2.28	1.26	2.20	3.86	3.35	9.84	7	
SCS 903 P	44	16-19	5/8 - 3/4	3.54	6.30	1.57	0.87	1.38	0.63	1.50	2.76	1.57	2.56	4.49	3.74	11.42	11	
SCS 904 P	61	20-22	7/8	4.21	7.24	1.77	1.00	1.61	0.75	1.73	3.15	1.73	3.03	5.12	4.33	13.23	17	
SCS 905 P	83	23-26	1	4.53	8.31	2.36	1.20	1.97	0.87	2.01	4.09	2.05	3.46	5.59	5.04	15.20	26	
SCS 906 P	99	27-29	1 1/8	5.51	8.46	2.56	1.34	2.24	0.98	2.24	4.49	2.28	3.78	6.26	5.59	16.54	35	
SCS 907 P	138	30-32	1 1/4	5.91	10.24	2.87	1.43	2.48	1.10	2.48	4.96	2.52	4.33	6.97	6.10	19.02	51	
SCS 908 P	138	33-36	1 3/8	6.69	10.24	2.87	1.56	2.52	1.10	2.72	4.96	2.68	4.49	7.76	6.30	19.80	55	
SCS 902 P.SR	28	13-16	1/2 - 5/8	3.35	5.24	1.26	0.75	1.18	0.55	1.26	2.28	1.26	2.20	3.86	3.35	9.84	7	
SCS 903 P.SR	44	16-19	5/8 - 3/4	3.54	6.30	1.57	0.87	1.38	0.63	1.50	2.76	1.57	2.56	4.49	3.74	11.42	11	
SCS 904 P.SR	61	20-22	7/8	4.21	7.24	1.77	1.00	1.61	0.75	1.73	3.15	1.73	3.03	5.12	4.33	13.23	17	
SCS 905 P.SR	83	23-26	1	4.53	8.31	2.36	1.20	1.97	0.87	2.01	4.09	2.05	3.46	5.59	5.04	15.20	26	
SCS 906 P.SR	99	27-29	1 1/8	5.51	8.46	2.56	1.34	2.24	0.98	2.24	4.49	2.28	3.78	6.26	5.59	16.54	35	
SCS 907 P.SR	138	30-32	1 1/4	5.91	10.24	2.87	1.43	2.48	1.10	2.48	4.96	2.52	4.33	6.97	6.10	19.02	51	
SCS 908 P.SR	138	33-36	1 3/8	6.69	10.24	2.87	1.56	2.52	1.10	2.72	4.96	2.68	4.49	7.76	6.30	19.80	55	
SCS 909 P.SR	165	37-39	1 1/2	-	-	-	-	-	-	-	-	-	-	-	-	-	-	
SCS 910 P.SR	187	40-42	1 5/8	-	-	-	-	-	-	-	-	-	-	-	-	-	-	
SCS 911 P.SR	248	43-48	1 3/4 - 1 7/8	-	-	-	-	-	-	-	-	-	-	-	-	-	-	
SCS 912 P.SR	309	49-54	2 - 2 1/2	8.86	14.69	4.25	2.36	3.74	1.77	3.98	7.64	4.13	7.28	11.02	9.61	27.80	205	

MBL = Minimum Breaking Load

- The standard finish of the sockets is blue primer coating and hot dipped galvanized.
- All sockets are provided with an EN 10204-2.1 declaration of conformity and EN 10204-3.1 material certificate.
- Dimensional tolerances are ±5% for the jaw opening (W) and pin diameter (øP).
- For other dimensional tolerances please contact Ropeblock.
- Surface finish e.g. hot dip galvanizing or paint may add to the overall thickness and fork distance.

SEE OUR WARNING & SAFETY INFORMATION ON PAGES 136 - 149

