

FAST CONNECTOR SOCKETS WITH BOLT AND NUT

**QUENCHED AND
TEMPERED CAST STEEL**

SOCKETS

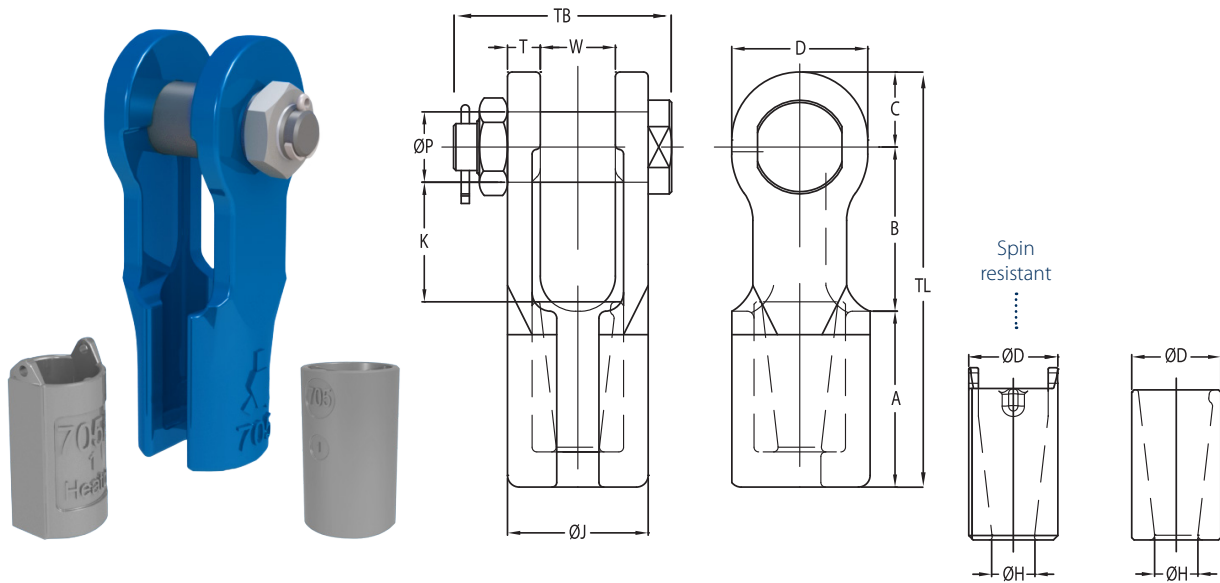

Model No.	Reeving aid	MBL (UStons)	for wire ø		Dimensions (inch)													Weight (lbs)
			(mm)	(inch)	A	B	C	øH	øP	T	W	D	øD	øJ	K	TB	TL	
FCS 701 B	-	22	11-13	7/16 - 1/2	2.44	2.40	1.06	0.59	0.98	0.47	0.98	1.97	1.30	1.93	1.81	3.15	5.91	4
FCS 702 B	-	28	13-16	1/2 - 5/8	2.83	3.07	1.26	0.71	1.18	0.55	1.26	2.28	1.50	2.36	2.32	3.78	7.17	6
FCS 703 B	-	44	16-19	5/8 - 3/4	3.35	3.66	1.57	0.83	1.38	0.63	1.50	2.76	1.77	2.76	2.72	4.21	8.58	10
FCS 704 B	-	61	20-22	7/8	4.02	4.17	1.77	0.94	1.61	0.75	1.73	3.15	1.97	3.23	3.19	4.84	9.96	14
FCS 705 B	-	83	23-26	1	4.53	4.84	2.36	1.10	2.01	0.87	2.01	4.09	2.36	3.74	3.54	5.43	11.73	24
FCS 706 B	-	99	27-29	1 1/8	5.51	5.98	2.56	1.26	2.24	0.98	2.24	4.49	2.76	4.21	4.57	6.30	14.06	35
FCS 705 B.SR	T 705	83	23-26	1	4.53	4.84	2.36	1.10	2.01	0.87	2.01	4.09	2.36	3.74	3.54	5.43	11.73	24
FCS 706 B.SR	T 706	99	27-29	1 1/8	5.51	5.98	2.56	1.26	2.24	0.98	2.24	4.49	2.76	4.21	4.57	6.30	14.06	35
FCS 707 B.SR	T 706	138	30-32	1 1/4	5.91	6.26	2.87	1.42	2.48	1.10	2.48	4.96	3.15	4.69	4.72	6.50	15.04	40
FCS 708 B.SR	T 706	138	33-36	1 3/8	6.30	6.73	2.87	1.54	2.52	1.10	2.72	4.96	3.35	4.92	5.12	7.28	15.91	51
FCS 709 B.SR	T 709	165	37-39	1 1/2	6.93	7.36	3.15	1.65	2.76	1.18	2.99	5.59	3.54	5.35	5.59	7.91	17.44	64
FCS 710 B.SR	T 709	187	40-42	1 5/8	7.40	7.80	3.46	1.77	2.99	1.30	2.99	6.14	3.74	5.59	5.91	8.23	18.66	79
FCS 711 B.SR	T 711	248	43-48	1 3/4 - 1 7/8	8.27	9.13	3.94	2.05	3.50	1.54	3.50	6.93	4.33	6.57	6.89	9.33	21.34	128

MBL = Minimum Breaking Load

- The standard finish of the sockets is blue primer coating and hot dipped galvanized.
- All sockets are provided with an EN 10204-2.1 declaration of conformity and EN 10204-3.1 material certificate.
- Dimensional tolerances are ±5% for the jaw opening (W) and pin diameter (øP).
- For other dimensional tolerances please contact Ropeblock.
- Surface finish e.g. hot dip galvanizing or paint may add to the overall thickness and fork distance.

SEE OUR WARNING & SAFETY INFORMATION ON PAGES 136 - 149



Available with
Reeving tool
(optional)

SEE OUR WARNING AND SAFETY INFORMATION ON PAGE 136

