

OPEN SPELTER SOCKETS WITH PIN

QUENCHED AND TEMPERED CAST STEEL

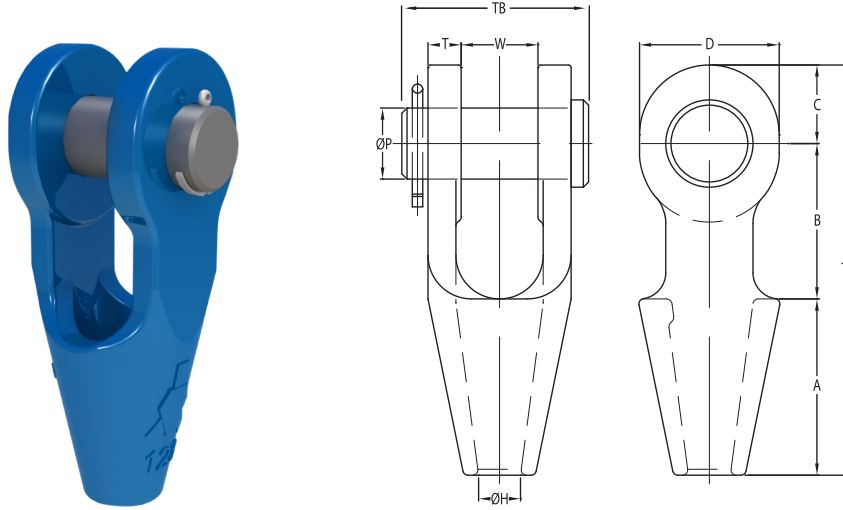

Model No.	MBL (UStons)	for wire ø		Strand ø		Dimensions (inch)										Weight (lbs)
		(mm)	(inch)	(mm)	(inch)	A	B	C	D	øH	øP	T	TL	TB	W	
OSS 196 P	9	6-7	¼	-	-	1.97	1.57	0.75	1.34	0.36	0.63	0.35	4.29	2.01	0.75	0.9
OSS 197 P	13	8-10	⅜	-	-	2.24	1.77	0.87	1.65	0.49	0.79	0.43	4.88	2.48	0.83	1.5
OSS 198 P	22	11-13	7/16 - ½	-	-	2.50	2.01	1.06	1.97	0.57	0.98	0.46	5.57	2.64	1.00	2.2
OSS 199 P	28	14-16	9/16 - 5/8	13	½	2.99	2.48	1.26	2.28	0.71	1.18	0.55	6.73	3.35	1.26	4.0
OSS 100 P	44	18-19	¾	14 - 16	9/16 - 5/8	3.50	2.99	1.57	2.76	0.86	1.38	0.63	8.07	3.74	1.50	7
OSS 104 P	61	20-22	7/8	18 - 19	¾	3.98	3.50	1.77	3.15	0.98	1.61	0.75	9.25	4.33	1.73	10
OSS 108 P	83	23-26	1	20 - 22	7/8	4.49	3.98	2.36	4.09	1.13	2.01	0.87	10.83	5.04	2.01	18
OSS 111 P	99	27-30	1 1/8	23 - 26	1	5.00	4.49	2.56	4.49	1.29	2.24	0.98	12.05	5.59	2.24	24
OSS 115 P	138	31-36	1 1/4 - 1 3/8	27 - 28	1 1/16 - 1 1/8	5.47	5.00	2.83	4.96	1.54	2.48	1.10	13.31	6.10	2.48	34
OSS 118 P	165	37-39	1 1/2	30 - 32	1 3/16 - 1 1/4	5.98	6.38	3.15	5.59	1.67	2.76	1.18	15.51	6.97	2.99	48
OSS 120 P	187	40-42	1 5/8	33 - 35	1 5/16 - 1 3/8	6.50	6.50	3.46	6.14	1.79	2.99	1.30	16.46	7.36	2.99	60
OSS 125 P	248	43-48	1 3/4 - 1 7/8	36 - 40	1 7/16 - 1 5/8	7.52	7.01	3.94	6.93	2.06	3.50	1.54	18.46	8.46	3.50	90
OSS 128 P	309	49-54	2 - 2 1/8	42 - 45	1 5/8 - 1 3/4	8.50	8.98	4.25	7.64	2.32	3.74	1.77	21.73	9.61	3.98	132
OSS 130 P	397	55-60	2 1/4 - 2 3/8	46 - 48	1 13/16 - 1 7/8	9.02	10.00	4.72	8.27	2.54	4.25	2.09	23.74	10.83	4.45	194
OSS 132 P	468	61-68	2 1/2 - 2 5/8	50 - 54	2 - 2 1/8	9.76	10.75	5.24	9.29	2.96	4.76	2.36	25.75	11.81	5.00	261
OSS 135 P	507	69-75	2 3/4 - 2 7/8	56 - 62	2 1/4 - 2 1/2	10.98	10.98	5.43	9.45	3.20	5.00	2.87	27.40	13.19	5.24	342
OSS 138 P	617	76-80	3 - 3 1/8	64 - 67	2 1/2 - 2 5/8	12.01	11.26	5.75	9.92	3.47	5.24	2.99	29.02	13.98	5.75	410
OSS 140 P	689	81-86	3 1/4 - 3 3/8	69 - 76	2 3/4 - 3	12.99	11.73	6.30	11.42	3.63	5.51	3.11	31.02	14.76	6.26	499
OSS 142 P	794	87-93	3 1/2 - 3 3/8	78 - 86	3 1/16 - 3 3/8	14.02	12.52	6.99	12.60	3.91	5.98	3.27	33.52	15.75	6.73	624
OSS 144 P	965	94-102	3 3/4 - 4	88 - 96	3 1/16 - 3 3/4	15.00	13.50	7.48	13.78	4.24	7.01	3.50	35.98	17.13	7.52	825
OSS 146 P	1323	108-115	4 1/4 - 4 1/2	98 - 110	3 7/8 - 4 5/16	17.72	18.90	8.46	15.75	5.09	7.68	3.94	45.08	18.31	8.07	1188
OSS 150 P	1543	120-130	4 3/4 - 5	112 - 124	4 7/16 - 4 7/8	19.69	19.69	9.84	17.72	5.78	8.66	4.33	49.21	20.67	8.86	1678
OSS 155 P	1764	135-140	5 1/4 - 5 1/2	125 - 132	4 15/16 - 5 3/16	21.26	19.57	10.35	18.90	6.06	9.45	5.51	51.18	23.23	9.06	2352
OSS 160 P	2205	142-153	5 3/4 - 6	133 - 143	5 1/4 - 5 5/8	23.03	19.88	10.83	19.69	6.73	10.04	5.51	53.74	24.02	9.84	2584
OSS 165 P	2447	154-165	6 1/4 - 6 1/2	144 - 154	5 1/16 - 6 1/4	24.80	20.87	11.81	21.65	7.28	10.83	5.91	57.48	25.20	10.24	3177
OSS 170 P	2756	166-178	6 3/4 - 7	155 - 166	6 1/4 - 6 3/4	26.77	22.44	12.20	22.44	7.83	11.61	5.91	61.42	25.98	11.02	3560
OSS 175 P	3086	180-191	7 1/4 - 7 1/2	167 - 179	6 9/16 - 7 1/16	28.54	23.62	12.80	23.62	8.39	12.20	6.10	64.96	27.13	11.81	4204
OSS 180 P	3527	192-204	7 3/4 - 8	180 - 191	7 1/4 - 7 1/2	30.51	24.41	13.58	25.20	9.02	12.99	6.30	68.50	28.35	12.60	4936

MBL = Minimum Breaking Load

- The standard finish of the sockets is blue primer coating and hot dipped galvanized (OSS 196 until OSS 100 only galvanized)
- All sockets are provided with an EN 10204-2.1 declaration of conformity and EN 10204-3.1 material certificate.
- Dimensional tolerances are ±5% for the jaw opening (W) and pin diameter (øP).
- For other dimensional tolerances please contact Ropeblock.
- Surface finish e.g. hot dip galvanizing or paint may add to the overall thickness and fork distance.

