



SHEAVES

SHEAVES MADE SMART

Sheaves are key factors in terms of the performance of your application and the lifetime of the wire rope installed. That's why Ropeblock focuses on finding the best possible design and materials for each specific application. In many cases our cast sheaves are the solution of choice, if only because of their self-lubricating properties.

However, when weight is a paramount factor, our plastic sheaves could be the answer you are looking for. In some cases a welded sheave, a forged sheave or a sheave made out of solid material might be the appropriate choice.

Mind you, whatever the right Ropeblock sheave may be in your case, you can count on its being engineered for efficiency. Our extensive knowledge and experience allow us to employ Smart Engineering, creating highly functional solutions that will meet your needs in every respect.

Although the list of standard sheaves is extensive, specific factors such as wire rope type & diameter, wrap angle, fleet angle, line pull and application details should be considered. Please contact us in order to determine which sheave most suits your purposes.



Find more details about the graphite lubrication effect in this cast sheave on pages 8 & 9.



CAST SHEAVES

Ropeblock self-lubricating cast sheaves are often applied in lifting, luffing and wire rope routing with intensive operating cycles. The groove opening angle was carefully designed to reduce potential twist resulting from fleet angles. In combination with the self-lubricating effect, the wire rope in your system will last longer. The latter was proved in recent research, in which several sheave materials were compared in terms of their effect on rope twist. Details of this research, which was carried out in cooperation with a leading German University, can be found in the Research and

Development section in this catalogue. It should come as no surprise that Ropeblock has been using these sheaves in most blocks for over 25 years. In most cases our standard sheaves can be fine-tuned to suit your application with only minor modifications. The full range of standard cast sheaves can be found on the following pages.

NEXT TO OUR LARGE RANGE OF STANDARD SHEAVES WE WILL GLADLY INVESTIGATE WHETHER AN ENGINEERED SOLUTION, SPECIFICALLY DESIGNED FOR YOUR APPLICATION, COULD BE A GOOD SOLUTION AS WELL.

AVAILABLE FINISHES (DEPENDS ON THE APPLICATION)

Segment / application	ISO 12944 classification	Classification description	Expected protection duration	DFT (µm)
Construction	C2M	Slightly polluted atmosphere, predominately agriculture areas	5 to 15 year	120
Construction	C3M	Industrial and residential air pollution levels, with an average sulfur dioxide (IV) contamination level. Coastal areas with low salt content in air	2 to 5 year	120
Construction	C3M	Industrial and residential air pollution levels, with an average sulfur dioxide (IV) contamination level. Coastal areas with low salt content in air	5 to 15 year	160
Cargo handling	C3M	Industrial and residential air pollution levels, with an average sulfur dioxide (IV) contamination level. Coastal areas with low salt content in air	5 to 15 year	160
Cargo handling	C4H	Industrial areas and coastal areas with average salt content in air	more than 15 year	280
Cargo handling	C5-MM	Coastal areas and open sea with high salt content in air	5 to 15 year	280
Offshore	C4H	Industrial areas and coastal areas with average salt content in air	more than 15 year	300
Offshore	C5-MM	Coastal areas and open sea with high salt content in air	5 to 15 year	300
Offshore	C5-MH	Coastal areas and open sea with high salt content in air	more than 15 year	320
Offshore	NORSOK sys. 1*	Open sea with high salt content in air	more than 15 year	300



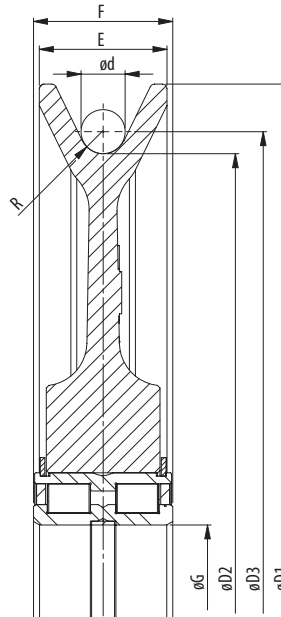

Model No.	Dimensions (inch)								Bearing	Weight (lbs)
	Sheave tread ø	Shaft ø	For wire ød	Groove radius	Outer ø	P.C.D.	Rim width	Bearing width		
	øD2	øG	d	R	øD1	øD3	E	F		
SE.225.5012.7,5	8.86	2.36	0.55	0.30	10.24	9.41	1.50	1.81	SL04 5012 PP	15
SE.227.5010.7	8.94	1.97	0.51	0.28	10.43	9.45	1.38	1.57	SL04 5010 PP	12
SE.250.5008B.6	9.84	1.57	0.43	0.24	11.42	10.28	1.26	1.50	SL04 5008 PP	13
SE.250.5008B.5,5	9.84	1.57	0.39	0.22	11.42	10.24	1.26	1.50	SL04 5008 PP	13
SE.250.5008B.7,2	9.84	1.57	0.51	0.28	11.42	10.35	1.26	1.50	SL04 5008 PP	14
SE.260.5012.8,5	10.24	2.36	0.63	0.33	11.81	10.87	1.65	1.81	SL04 5012 PP	20
SE.260.5012.6,5	10.24	2.36	0.47	0.26	11.81	10.71	1.65	1.81	SL04 5012 PP	21
SE.260.5012.7,5	10.24	2.36	0.55	0.30	11.81	10.79	1.65	1.81	SL04 5012 PP	21
SE.280.5010.7	11.02	1.97	0.51	0.28	12.60	11.54	1.42	1.57	SL04 5010 PP	18
SE.280.5010B.7	11.02	1.97	0.51	0.28	12.60	11.54	1.42	1.57	SL04 5010 PP	18
SE.280.5012.8,5	11.02	2.36	0.63	0.33	12.60	11.65	1.65	1.81	SL04 5012 PP	20
SE.280.5012.8	11.02	2.36	0.59	0.31	12.60	11.61	1.65	1.81	SL04 5012 PP	20
SE.280.5012.7	11.02	2.36	0.51	0.28	12.60	11.54	1.65	1.81	SL04 5012 PP	21
SE.280.5012.10	11.02	2.36	0.75	0.39	12.60	11.77	1.65	1.81	SL04 5012 PP	23
SE.280.4914.8,5	11.02	2.76	0.63	0.33	12.60	11.65	1.42	2.36	SL01 4914 ZZ	19
SE.280.4914.7	11.02	2.76	0.51	0.28	12.60	11.54	1.42	1.18	SL01 4914 ZZ	20
SE.295.5008B.8,5	11.61	1.57	0.63	0.33	12.99	12.24	1.26	1.50	SL04 5008 PP	19
SE.300.5008.7	11.81	1.57	0.51	0.28	13.78	12.32	1.38	1.50	SL04 5008 PP	15
SE.300.5010.7	11.81	1.97	0.51	0.28	13.78	12.32	1.50	1.57	SL04 5008 PP	15
SE.320.5011.8,8,M	12.60	2.17	0.63	0.35	15.12	13.23	1.69	1.81	SL04 5011 PP	23
SE.320.4914.8,5	12.60	2.17	0.63	0.33	15.12	13.23	1.69	1.81	SL01 4914	28
SE.320.5013.9	12.60	2.56	0.67	0.35	15.12	13.27	1.69	1.81	SL04 5013 PP	29
SE.320.5013.10	12.60	2.56	0.75	0.39	14.37	13.35	1.65	1.81	SL04 5013 PP	29



- The dimensions in this table are indicative only. A drawing will always be submitted prior to production and will be the leading document when discussing dimensions.
- Sheaves shown here are standard models; inquiries for custom versions are welcome.



SEE OUR WARNING & SAFETY
INFORMATION ON PAGES 136 - 149



Model No.	Dimensions (inch)								Bearing	Weight (lbs)
	Sheave tread ø	Shaft ø	For wire ød	Groove radius	Outer ø	P.C.D.	Rim width	Bearing width		
	øD2	øG	d	R	øD1	øD3	E	F		



SE.320.5013.8,5	12.60	2.56	0.63	0.33	14.37	13.23	1.65	1.81	SL04 5013PP	30
SE.345.5010B.9,5	13.58	1.97	0.71	0.37	15.16	14.29	1.42	1.57	SL04 5010 PP	28
SE.345.5010B.10	13.58	1.97	0.75	0.39	15.16	14.33	1.42	1.57	SL04 5010 PP	28
SE.350.5012.8	13.78	2.36	0.55	0.31	16.34	14.33	1.77	1.81	SL04 5012 PP	28
SE.354.5013.9,5	13.94	2.56	0.71	0.37	15.75	14.65	1.65	1.81	SL04 5013 PP	36
SE.355.5013.10	13.98	2.56	0.75	0.39	16.14	14.72	1.65	1.81	SL04 5013 PP	39
SE.355.5013.9,5	13.98	2.56	0.71	0.37	16.14	14.69	1.65	1.81	SL04 5013 PP	40
SE.355.5013.9	13.98	2.56	0.67	0.35	16.14	14.65	1.65	1.81	SL04 5013 PP	40
SE.355.5013.8,5	13.98	2.56	0.63	0.33	16.14	14.61	1.65	1.81	SL04 5013 PP	40
SE.355.5016.7,5	13.98	3.15	0.55	0.30	16.14	14.53	2.17	2.36	SL04 5016 PP	37
SE.355.5016.10	13.98	3.15	0.75	0.39	16.14	14.72	2.17	2.36	SL04 5016 PP	37
SE.355.5016.12	13.98	3.15	0.87	0.47	16.14	14.84	2.17	2.36	SL04 5016 PP	37
SE.355.4918.12	13.98	3.54	0.87	0.47	16.14	14.84	1.73	1.38	SL01 4918 ZZ	33
SE.355.4918.9	13.98	3.54	0.67	0.35	16.14	14.65	1.73	1.38	SL01 4918 ZZ	35
SE.355.4918.8,5	13.98	3.54	0.63	0.33	16.14	14.61	1.73	1.38	SL01 4918 ZZ	36
SE.355.4918.9,5	13.98	3.54	0.71	0.37	16.14	14.69	1.73	1.38	SL01 4918 ZZ	39
SE.355.4918.10	13.98	3.54	0.75	0.39	16.14	14.72	1.73	1.38	SL01 4918 ZZ	40
SE.355.4926.9	13.98	5.12	0.67	0.35	16.14	14.65	2.32	1.97	SL01 4926 PP	51
SE.360.5016.10	14.17	3.15	0.75	0.39	16.54	14.92	2.17	2.36	SL04 5016 PP	39
SE.360.5016.9,5	14.17	3.15	0.71	0.37	16.54	14.88	2.17	2.36	SL04 5016 PP	48
SE.360.5016.8,5	14.17	3.15	0.63	0.33	16.54	14.80	2.17	2.36	SL04 5016 PP	48
SE.360.4918.10	14.17	3.54	0.75	0.39	16.54	14.92	1.73	1.38	SL01 4918 ZZ	41
SE.360.4918.9,5	14.17	3.54	0.71	0.37	16.54	14.88	1.73	1.38	SL01 4918 ZZ	41
SE.360.4918.8,5	14.17	3.54	0.63	0.33	16.54	14.80	1.73	1.38	SL01 4918 ZZ	42
SE.373.5018.12	14.69	3.54	0.87	0.47	17.32	15.55	2.01	2.64	SL04 5018 PP	54
SE.400.5013.10	15.75	2.56	0.75	0.39	18.11	16.50	1.69	1.81	SL04 5013 PP	55
SE.400.5013.9,5	15.75	2.56	0.71	0.37	18.11	16.46	1.69	1.81	SL04 5013 PP	55
SE.400.5013.8,5	15.75	2.56	0.63	0.33	18.11	16.38	1.69	1.81	SL04 5013 PP	56
SE.400.5014B.11,5	15.75	2.76	0.83	0.45	18.11	16.57	1.93	2.13	SL04 5014 PP	54
SE.400.5014B.10	15.75	2.76	0.75	0.39	18.11	16.50	1.93	2.13	SL04 5014 PP	55
SE.400.5014B.9,5	15.75	2.76	0.71	0.37	18.11	16.46	1.93	2.13	SL04 5014 PP	56
SE.400.5016.12.A	15.75	3.15	0.87	0.47	18.11	16.61	1.97	2.36	SL04 5016 PP	56
SE.400.5016.15	15.75	3.15	1.10	0.59	18.11	16.85	2.83	2.36	SL04 160 PP	62
SE.400.5016.12	15.75	3.15	0.87	0.47	18.11	16.61	2.17	2.36	SL04 5016 PP	62
SE.400.5016.11,5	15.75	3.15	0.83	0.45	18.11	16.57	2.17	2.36	SL04 5016 PP	62
SE.400.5016.10	15.75	3.15	0.75	0.39	18.11	16.50	2.17	2.36	SL04 5016 PP	63
SE.400.4918.10	15.75	3.54	0.75	0.39	18.11	16.50	1.73	1.38	SL01 4918 ZZ	57
SE.400.5018.9,5	15.75	3.54	0.71	0.37	18.11	16.46	2.83	2.64	SL04 160 PP	62
SE.400.5018.12	15.75	3.54	0.87	0.47	18.11	16.61	2.44	2.64	SL04 5018 PP	66
SE.400.5018.11,5	15.75	3.54	0.83	0.45	18.11	16.57	2.44	2.64	SL04 5018 PP	67
SE.400.5018.10	15.75	3.54	0.75	0.39	18.11	16.50	2.44	2.64	SL04 5018 PP	68
SE.400.4922.10	15.75	4.33	0.75	0.39	18.11	16.50	1.97	1.57	SL01 4922 PP	56



- The dimensions in this table are indicative only. A drawing will always be submitted prior to production and will be the leading document when discussing dimensions.
- Sheaves shown here are standard models; inquiries for custom versions are welcome.



SEE OUR WARNING & SAFETY INFORMATION ON PAGES 136 - 149



Model No.	Dimensions (inch)								Bearing	Weight (lbs)
	Sheave tread ϕ	Shaft ϕ	For wire ϕ d	Groove radius	Outer ϕ	P.C.D.	Rim width	Bearing width		
	ϕ D2	ϕ G	d	R	ϕ D1	ϕ D3	E	F		
SE.400.4924.10	15.75	4.72	0.75	0.39	18.11	16.50	2.17	1.77	SL04 160 PP	56
SE.400.160.9,5	15.75	6.30	0.71	0.37	18.11	16.46	2.83	3.15	SL04 160 PP	74
SE.400.160.12	15.75	6.30	0.87	0.47	18.11	16.61	2.83	3.15	SL04 160 PP	74
SE.438.5018.12	17.24	3.54	0.87	0.47	19.69	18.11	2.28	2.64	SL04 5018 PP	61
SE.450.5018.15	17.72	3.54	1.10	0.59	20.28	18.82	2.44	2.64	SL04 5018 PP	86
SE.450.5018.13,5	17.72	3.54	0.98	0.53	20.28	18.70	2.44	2.64	SL04 5018 PP	88
SE.450.5018.12	17.72	3.54	0.87	0.47	20.28	18.58	2.44	2.64	SL04 5018 PP	89
SE.450.5018.10	17.72	3.54	0.75	0.39	20.28	18.46	2.44	2.64	SL04 5018 PP	91
SE.450.5018.10,5	17.72	3.54	0.79	0.41	20.28	18.50	2.44	2.64	SL04 5018 PP	91
SE.450.5018.13	17.72	3.54	0.94	0.51	20.28	18.66	2.44	2.64	SL04 5018 PP	91
SE.450.5024.15	17.72	4.72	1.10	0.59	20.28	18.82	2.95	3.15	SL04 5024 PP	100
SE.450.5024.13,5	17.72	4.72	0.98	0.53	20.28	18.70	2.95	3.15	SL04 5024 PP	102
SE.450.5024.12	17.72	4.72	0.87	0.47	20.28	18.58	2.95	3.15	SL04 5024 PP	103
SE.450.5024.10	17.72	4.72	0.75	0.39	20.28	18.46	2.95	3.15	SL04 5024 PP	105
SE.450.4926.12	17.72	5.12	0.87	0.47	20.28	18.58	2.36	1.97	SL01 4926 PP	83
SE.450.4926.10	17.72	5.12	0.75	0.39	20.28	18.46	2.36	1.97	SL01 4926 PP	84
SE.450.4926.13,5	17.72	5.12	0.98	0.53	20.28	18.70	2.36	1.97	SL01 4926 PP	92
SE.450.4830.10	17.72	5.91	0.75	0.39	20.28	18.46	2.17	1.57	SL01 4830	78
SE.450.160.10	17.72	6.30	0.75	0.39	20.28	18.46	2.95	3.15	SL04 160 PP	100
SE.482.5018.11	18.98	3.54	0.79	0.45	22.05	19.76	2.44	2.64	SL04 5018 PP	100
SE.482.5018.11,5	18.98	3.54	0.83	0.45	22.05	19.80	2.44	2.64	SL04 5018 PP	100
SE.482.5018.12	18.98	3.54	0.83	0.45	22.05	19.80	2.44	2.64	SL04 5018 PP	100
SE.482.5018.10,5	18.98	3.54	0.79	0.41	22.05	19.76	2.44	2.64	SL04 5018 PP	101
SE.482.5024.11	18.98	4.72	0.79	0.43	22.05	19.76	2.44	3.15	SL04 5024 PP	110
SE.482.160.11	18.98	6.30	0.79	0.43	22.05	19.76	2.44	3.15	SL04 160 PP	108
SE.500.5018B.13,5	19.69	3.54	0.98	0.53	22.44	20.67	2.40	2.64	SL04 5018 PP	103
SE.511.5020.10.M	20.12	3.94	0.75	0.39	22.99	20.87	2.24	2.64	SL04 5020 PP	63
SE.528.5018.14	20.79	3.54	1.02	0.55	23.43	21.81	2.40	2.64	SL04 5018 PP	100
SE.528.5018.15	20.79	3.54	1.10	0.59	23.43	21.89	2.40	2.64	SL04 5018 PP	110
SE.528.5018.13,5	20.79	3.54	0.98	0.53	23.43	21.77	2.40	2.64	SL04 5018 PP	111
SE.528.5018.12	20.79	3.54	0.87	0.47	23.43	21.65	2.40	2.64	SL04 5018 PP	112
SE.528.5018.13	20.79	3.54	0.94	0.51	23.43	21.73	2.40	2.64	SL04 5018 PP	112
SE.528.5018.14.B	20.79	3.54	1.02	0.55	23.43	21.81	2.40	2.64	SL04 5018 PP	112
SE.528.5024.15	20.79	4.72	1.10	0.59	23.43	21.89	2.91	3.15	SL04 5024 PP	125
SE.528.5024.13,5	20.79	4.72	0.98	0.53	23.43	21.77	2.91	3.15	SL04 5024 PP	127
SE.528.5024.14	20.79	4.72	1.02	0.55	23.43	21.81	2.91	3.15	SL04 5024 PP	140
SE.528.160.15	20.79	6.30	1.10	0.59	23.43	21.89	2.83	3.15	SL04 160 PP	116
SE.528.160.14	20.79	6.30	1.02	0.55	23.43	21.81	2.91	3.15	SL04 160 PP	117
SE.528.160.13,5	20.79	6.30	0.98	0.53	23.43	21.77	2.91	3.15	SL04 160 PP	118
SE.528.160.13	20.79	6.30	0.94	0.51	23.43	21.73	2.91	3.15	SL04 160 PP	135
SE.528.4836.13	20.79	7.09	0.94	0.51	23.43	21.73	2.32	1.77	SL01 4836 PP	105
SE.528.200.13	20.79	7.87	0.94	0.51	23.43	21.73	2.91	3.15	SL04 200 PP	125



- The dimensions in this table are indicative only. A drawing will always be submitted prior to production and will be the leading document when discussing dimensions.
- Sheaves shown here are standard models; inquiries for custom versions are welcome.



Model No.	Dimensions (inch)								Bearing	Weight (lbs)
	Sheave tread ø	Shaft ø	For wire ød	Groove radius	Outer ø	P.C.D.	Rim width	Bearing width		
	øD2	øG	d	R	øD1	øD3	E	F		



SE.528.200.13,5	20.79	7.87	0.98	0.53	23.43	21.77	2.91	3.15	SL04 200 PP	125
SE.528.200.15	20.79	7.87	1.10	0.59	23.43	21.89	2.91	3.15	SL04 200 PP	143
SE.536.130.14.M	21.10	5.12	1.02	0.55	24.02	22.13	2.56	3.15	SL04 130 PP	99
SE.575.5022.16	22.64	4.33	1.18	0.63	25.59	23.82	2.91	3.15	SL04 5022 PP	159
SE.575.5022.14	22.64	4.33	1.02	0.55	25.59	23.66	2.91	3.15	SL04 5022 PP	162
SE.575.5022.15	22.64	4.33	1.10	0.59	25.59	23.74	2.91	3.15	SL04 5022 PP	162
SE.575.5024.17	22.64	4.72	1.26	0.67	25.59	23.90	2.91	3.15	SL04 5024 PP	156
SE.575.5024.15	22.64	4.72	1.10	0.59	25.59	23.74	2.91	3.15	SL04 5024 PP	158
SE.575.5024.16	22.64	4.72	1.18	0.63	25.59	23.82	2.91	3.15	SL04 5024 PP	158
SE.575.5024.14	22.64	4.72	1.02	0.55	25.59	23.66	2.91	3.15	SL04 5024 PP	160
SE.575.160.15	22.64	6.30	1.10	0.59	25.59	23.74	2.91	3.15	SL04 160 PP	157
SE.575.160.14	22.64	6.30	1.02	0.55	25.59	23.66	2.91	3.15	SL04 160 PP	158
SE.575.200.15	22.64	7.87	1.10	0.59	25.59	23.74	2.91	3.15	SL04 200 PP	167
SE.575.200.14	22.64	7.87	1.02	0.55	25.59	23.66	2.91	3.15	SL04 200 PP	169
SE.630.5022B.16	24.80	4.33	1.18	0.63	27.95	25.98	2.91	3.15	SL04 5022 PP	184
SE.630.5024.17	24.80	4.72	1.26	0.67	27.95	26.06	2.91	3.15	SL04 5024 PP	183
SE.630.5024.16	24.80	4.72	1.18	0.63	27.95	25.98	2.91	3.15	SL04 5024 PP	184
SE.630.5024.15	24.80	4.72	1.10	0.59	27.95	25.91	2.91	3.15	SL04 5024 PP	186
SE.630.160.17	24.80	6.30	1.26	0.67	27.95	26.06	2.91	3.15	SL04 160 PP	179
SE.630.160.16	24.80	6.30	1.18	0.63	27.95	25.98	2.91	3.15	SL04 160 PP	181
SE.630.160.15	24.80	6.30	1.10	0.59	27.95	25.91	2.91	3.15	SL04 160 PP	182
SE.630.200.17	24.80	7.87	1.26	0.67	27.95	26.06	2.91	3.15	SL04 200 PP	190
SE.630.200.16	24.80	7.87	1.18	0.63	27.95	25.98	2.91	3.15	SL04 200 PP	191
SE.630.200.15	24.80	7.87	1.10	0.59	27.95	25.91	2.91	3.15	SL04 200 PP	193
SE.646.5030.18	25.43	5.91	1.34	0.71	29.13	26.77	3.15	3.94	SL04 5030 PP	200
SE.670.5024.17	26.38	4.72	1.26	0.67	29.92	27.64	2.91	3.15	SL04 5024 PP	197
SE.670.5024.15	26.38	4.72	1.10	0.59	29.92	27.48	2.91	3.15	SL04 5024 PP	201
SE.670.5024.13,5	26.38	4.72	0.98	0.53	29.92	27.36	2.91	3.15	SL04 5024 PP	204
SE.670.160.17	26.38	6.30	1.26	0.67	29.92	27.64	2.91	3.15	SL04 160 PP	199
SE.670.160.15	26.38	6.30	1.10	0.59	29.92	27.48	2.91	3.15	SL04 160 PP	203
SE.670.160.13,5	26.38	6.30	0.98	0.53	29.92	27.36	2.91	3.15	SL04 160 PP	206
SE.670.200.13,5	26.38	7.87	0.98	0.53	29.92	27.36	2.91	3.15	SL04 200 PP	206
SE.670.200.17	26.38	7.87	1.26	0.67	29.92	27.64	2.91	3.15	SL04 200 PP	210
SE.670.200.15	26.38	7.87	1.10	0.59	29.92	27.48	2.91	3.15	SL04 200 PP	213
SE.685.5028.16	26.97	5.51	1.18	0.63	31.22	28.15	3.54	3.74	SL04 5028 PP	279
SE.685.5028.18	26.97	5.51	1.34	0.71	31.22	28.31	3.54	3.74	SL04 5028 PP	279
SE.688.5024.17	27.09	4.72	1.26	0.67	30.71	28.35	2.91	3.15	SL04 5024 PP	231
SE.688.5036.17	27.09	7.09	1.26	0.67	30.71	28.35	2.91	5.35	SL04 5036 PP	275
SE.710.5022.18	27.95	4.33	1.34	0.71	31.50	29.29	2.83	3.15	SL04 5022 PP	217
SE.710.5022.17	27.95	4.33	1.26	0.67	31.50	29.21	2.83	3.15	SL04 5022 PP	220
SE.710.5024.18	27.95	4.72	1.34	0.71	31.50	29.29	2.83	3.15	SL04 5024 PP	208
SE.710.5024.20	27.95	4.72	1.50	0.79	31.50	29.45	2.83	3.15	SL04 5024 PP	208



- The dimensions in this table are indicative only. A drawing will always be submitted prior to production and will be the leading document when discussing dimensions.
- Sheaves shown here are standard models; inquiries for custom versions are welcome.



SEE OUR WARNING & SAFETY INFORMATION ON PAGES 136 - 149



Model No.	Dimensions (inch)								Bearing	Weight (lbs)
	Sheave tread ϕ	Shaft ϕ	For wire ϕ d	Groove radius	Outer ϕ	P.C.D.	Rim width	Bearing width		
	ϕ D2	ϕ G	d	R	ϕ D1	ϕ D3	E	F		
SE.710.5026.18	27.95	5.12	1.34	0.71	31.50	29.29	3.07	3.74	SL04 5026 PP	216
SE.710.5028.18	27.95	5.51	1.34	0.71	31.89	29.29	3.35	3.74	SL04 5028 PP	235
SE.710.5028.17	27.95	5.51	1.26	0.67	31.89	29.21	3.35	3.74	SL04 5028 PP	237
SE.710.5030.18	27.95	5.91	1.34	0.71	31.89	29.29	3.54	3.94	SL04 5030 PP	238
SE.710.5030.17	27.95	5.91	1.26	0.67	31.89	29.21	3.54	3.94	SL04 5030 PP	240
SE.720.5030.18	28.35	5.91	1.34	0.71	32.68	29.69	3.54	3.94	SL04 5030 PP	248
SE.750.226.13	29.53	10.24	0.94	0.51	32.68	30.47	2.83	3.70	SL04 260 PP	358
SE.760.5026.20,5	29.92	5.12	1.54	0.81	33.86	31.46	2.95	3.74	SL04 5026 PP	304
SE.760.5030.20	29.92	5.91	1.50	0.79	33.86	31.42	3.35	3.94	SL04 5030 PP	295
SE.760.220.22	29.92	8.66	1.61	0.87	34.65	31.54	3.54	3.74	SL04 220 PP	314
SE.760.220.21	29.92	8.66	1.57	0.83	34.65	31.50	3.54	3.74	SL04 220 PP	317
SE.800.5022.16,5	31.50	4.33	1.22	0.63	35.04	32.72	2.76	3.15	SL04 5022 PP	300
SE.800.5024.16	31.50	4.72	1.18	0.63	35.04	32.68	2.76	3.15	SL04 5024 PP	280
SE.800.5024.20	31.50	4.72	1.50	0.79	35.04	32.99	2.76	3.15	SL04 5024 PP	280
SE.800.5026.17	31.50	5.12	1.26	0.67	35.04	32.76	2.95	3.74	SL04 5026 PP	286
SE.800.5026.18	31.50	5.12	1.34	0.71	35.04	32.83	2.95	3.74	SL04 5026 PP	294
SE.800.5026.20	31.50	5.12	1.50	0.79	35.04	32.99	2.95	3.74	SL04 5026 PP	294
SE.800.5028.22,5	31.50	5.51	1.65	0.89	35.04	33.15	3.35	3.74	SL04 5028 PP	328
SE.800.5028.21	31.50	5.51	1.57	0.83	35.04	33.07	3.35	3.74	SL04 5028 PP	331
SE.800.5028.20	31.50	5.51	1.50	0.79	35.04	32.99	3.35	3.74	SL04 5028 PP	333
SE.800.5028.19	31.50	5.51	1.42	0.75	35.04	32.91	3.35	3.74	SL04 5028 PP	335
SE.800.5030.23,5	31.50	5.91	1.73	0.93	35.04	33.23	3.54	3.94	SL04 5030 PP	329
SE.800.5030.21	31.50	5.91	1.57	0.83	35.04	33.07	3.54	3.94	SL04 5030 PP	335
SE.800.5030.20	31.50	5.91	1.50	0.79	35.04	32.99	3.54	3.94	SL04 5030 PP	337
SE.800.5030.22,5	31.50	5.91	1.65	0.89	35.04	33.15	3.54	3.94	SL04 5030 PP	352
SE.816.5028.18	32.13	5.51	1.34	0.71	36.06	33.46	3.15	3.74	SL04 5028 PP	321
SE.822.5026.15	32.36	5.12	1.10	0.59	35.67	33.46	2.95	3.74	SL04 5026 PP	277
SE.830.232.15	32.68	6.30	1.10	0.59	35.83	33.78	2.87	4.17	NJ-232-E	488
SE.850.232.15	33.46	6.30	1.10	0.59	37.01	34.57	3.15	4.17	NJ-232-E	438
SE.864.324.15	34.02	4.72	1.10	0.59	38.39	35.12	3.94	2.17	2x NJ-324-E	341
SE.864.324.19	34.02	4.72	1.42	0.75	38.39	35.43	3.94	2.17	2x NJ-324-E	341
SE.874.5036.23,5	34.41	7.09	1.73	0.93	39.53	36.14	4.21	5.35	SL04 5036 PP	563
SE.876.260.26,5	34.49	10.24	1.97	1.04	40.00	36.46	4.06	3.70	SL04 260 PP	527
SE.900.5026.19	35.43	5.12	1.42	0.75	39.76	36.85	3.43	3.74	SL04 5026 PP	385
SE.900.5030.22,5	35.43	5.91	1.65	0.89	39.76	37.09	3.43	3.94	SL04 5030 PP	389
SE.900.5030.23,5	35.43	5.91	1.73	0.93	39.76	37.17	3.43	3.94	SL04 5030 PP	389
SE.900.5030.25,5	35.43	5.91	1.89	1.00	39.76	37.32	3.43	3.94	SL04 5030 PP	389
SE.950.260.26,5	37.40	10.24	1.97	1.04	43.07	39.37	4.33	3.70	SL04 260 PP	560
SE.960.5034.21,5.H	37.80	6.69	1.57	0.85	42.52	39.37	4.33	4.80	SL04 5034 PP	565
SE.960.5034.23,5	37.80	6.69	1.73	0.93	42.52	39.53	4.33	4.80	SL04 5034 PP	565
SE.960.5036.21,5	37.80	7.09	1.57	0.85	42.52	39.37	4.33	5.35	SL04 5036 PP	572
SE.960.5036.21,5.H	37.80	7.09	1.57	0.85	42.52	39.37	4.33	5.35	SL04 5036 PP	579



- The dimensions in this table are indicative only. A drawing will always be submitted prior to production and will be the leading document when discussing dimensions.
- Sheaves shown here are standard models; inquiries for custom versions are welcome.



Model No.	Dimensions (inch)								Bearing	Weight (lbs)
	Sheave tread ø	Shaft ø	For wire ød	Groove radius	Outer ø	P.C.D.	Rim width	Bearing width		
	øD2	øG	d	R	øD1	øD3	E	F		
SE.960.5038.21,5	37.80	7.48	1.57	0.85	42.52	39.37	4.33	5.35	SL04 5038 PP	572
SE.960.5040.21,5,H	37.80	7.87	1.57	0.85	42.52	39.37	4.33	5.91	SL04 5040 PP	587
SE.1004.5030.27	39.53	5.91	2.01	1.07	44.06	41.54	3.74	3.94	SL04 5030 PP	436
SE.1010.5022.18,5	39.76	4.33	1.38	0.73	43.90	41.14	3.15	2.56	SL04 5022 PP	438
SE.1040.5034.30	40.94	6.69	2.20	1.18	46.46	43.15	4.49	4.80	SL04 5034PP	613
SE.1040.5034.23,5	40.94	6.69	1.73	0.93	46.46	42.68	4.33	3.90	SL04 5034 PP	634
SE.1040.5036.26,5	40.94	7.09	1.97	1.04	46.46	42.91	4.49	4.33	SL04 5036 PP	711
SE.1040.5038.30	40.94	7.48	2.20	1.18	46.46	43.15	4.49	5.35	SL04 5038PP	627
SE.1060.5044.37	41.73	8.66	2.76	1.46	47.24	44.49	5.51	5.87	SL04 5044 PP	1052
SE.1120.5034.29,5	44.09	6.69	2.17	1.16	50.39	46.26	4.92	3.90	SL04 5034 PP	876
SE.1120.5038.27	44.09	7.48	2.01	1.06	50.39	46.10	4.92	4.33	SL04 5038 PP	893
SE.1130.5044.27	44.49	8.66	2.01	1.06	51.18	46.50	5.75	5.12	SL04 5044 PP	1071
SE.1200.5040.27,5	47.24	7.87	2.05	1.08	53.94	49.29	5.51	4.72	SL04 5040PP	1140
SE.1200.5044.32	47.24	8.66	2.36	1.26	53.94	49.61	5.75	6.30	SL04 5044 PP	1124
SE.1250.5044.29	49.21	8.66	2.13	1.14	55.71	51.34	5.31	5.12	SL04 5044 PP	1459
SE.1280.5044.34	50.39	8.66	2.52	1.34	57.87	52.91	5.83	6.30	SL04 5044 PP	1373
SE.1280.5044.30	50.39	8.66	2.20	1.18	57.87	52.60	5.83	5.12	SL04 5044 PP	1384
SE.1280.5044.32	50.39	8.66	2.36	1.26	57.87	52.76	5.83	5.12	SL04 5044 PP	1384
SE.1445.5052.39,5	56.89	10.24	2.95	1.56	65.39	59.84	6.69	6.06	SL04 5052 PP	2246
SE.1540.5056.38	57.09	11.02	2.83	1.50	68.70	59.92	6.69	6.06	SL04 5056 PP	2486
SE.1820.5052.39,5	71.65	10.24	2.95	1.56	80.55	74.61	6.69	6.06	SL04 5052 PP	2933
SE.2660.5056.38	104.72	11.02	2.83	1.50	112.80	107.56	6.30	7.48	SL04 5056 PP	5101

- The dimensions in this table are indicative only. A drawing will always be submitted prior to production and will be the leading document when discussing dimensions.
- Sheaves shown here are standard models; inquiries for custom versions are welcome.



SEE OUR WARNING & SAFETY INFORMATION ON PAGES 136 - 149

CAST SHEAVES, RIGGING

WITH BALL BEARINGS

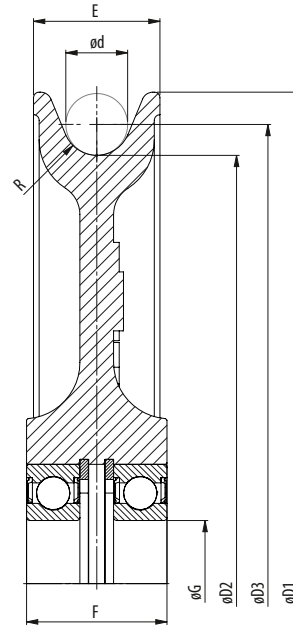

Model No.	Dimensions (inch)								Bearing	Weight (lbs)
	Sheave tread ø	Shaft ø	For wire ød	Groove radius	Outer ø	P.C.D.	Rim width	Bearing width		
	øD2	øG	d	R	øD1	øD3	E	F		
SEF.80.6002.4,5	3.15	0.59	0.31	0.18	3.94	3.46	0.71	0.79	2x6002-RS	2
SEF.105.60-22.5,5	4.13	0.87	0.39	0.22	4.92	4.53	0.91	1.08	2x6022-RS	3
SEF.120.6206.6,5	4.72	1.18	0.47	0.26	5.91	5.20	1.42	1.57	2x6206-RS	7
SEF.165.6206.7,5	6.50	1.18	0.55	0.30	7.87	7.05	1.42	1.57	2x6206-RS	10
SEF.210.6207.9,5	8.27	1.38	0.71	0.37	9.84	8.98	1.57	1.77	2x6207-RS	18
SEF.255.6208.11	10.04	1.57	0.79	0.43	11.81	10.83	1.77	1.97	2x6208-RS	26
SEF.305.6209.12	12.01	1.77	0.87	0.47	13.78	12.87	1.77	1.97	2x6209-RS	37
SEF.345.6210.13	13.58	1.97	0.94	0.51	15.75	14.53	2.17	2.36	2x6210-RS	53

- Different shaft sizes possible.
- Groove may be adjusted to other wire rope diameters.



SEE OUR WARNING & SAFETY
INFORMATION ON PAGES 136 - 149



CAST SHEAVES, RIGGING

WITH CYLINDRICAL ROLLER BEARINGS

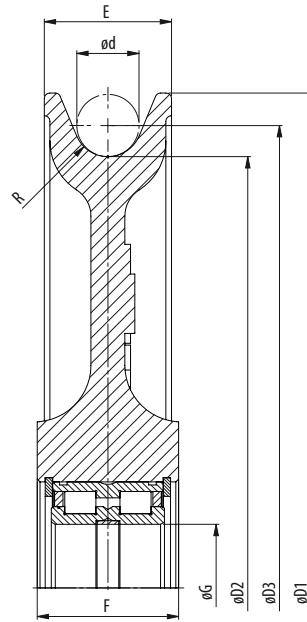

Model No.	Dimensions (inch)								Bearing	Weight (lbs)
	Sheave tread ø	Shaft ø	For wire ød	Groove radius	Outer ø	P.C.D.	Rim width	Bearing width		
	øD2	øG	d	R	øD1	øD3	E	F		
SEF.120.5005.6,5	4.72	0.98	0.47	0.26	5.91	5.20	1.42	1.57/1.18	SL04 5005 PP	15
SEF.120.5006.6,5	4.72	1.18	0.47	0.26	5.91	5.20	1.42	1.57/1.33	SL04 5006 PP	7
SEF.165.5006.7,5	6.50	1.18	0.55	0.30	7.87	7.05	1.42	1.57/1.33	SL04 5006 PP	10
SEF.195.5012.12	7.68	2.36	0.87	0.47	9.84	8.54	1.97	2.36	SL04 5012 PP	29
SEF.210.5007.9,5	8.27	1.38	0.71	0.37	9.84	8.98	1.57	1.77/1.41	SL04 5007 PP	18
SEF.255.5008.9,5	8.27	1.57	0.71	0.39	9.84	8.98	1.34	1.50	SL04 5008 PP	13
SEF.210.5008.6	8.27	1.57	0.43	0.24	9.84	8.70	1.34	1.50	SL04 5008 PP	14
SEF.210.5008.9,5	8.27	1.57	0.71	0.37	9.84	8.98	1.57	1.77/1.41	SL04 5008 PP	18
SEF.250.5013.13	9.84	2.56	0.94	0.51	11.81	10.79	2.17	2.36	SL04 5013 PP	29
SEF.255.5008.11	10.04	1.57	0.79	0.43	11.81	10.83	1.77	1.96/1.49	SL04 5008 PP	26
SEF.255.5010.8,5	10.04	1.97	0.63	0.33	11.81	10.67	1.42	1.57	SL04 5010 PP	19
SEF.305.5009.12	12.01	1.77	0.87	0.47	13.78	12.87	1.77	1.96/1.57	SL04 5009 PP	37
SEF.305.5012.8,5	12.01	2.36	0.63	0.33	13.78	12.64	1.77	1.81	SL04 5012 PP	30
SEF.305.5015.14	12.01	2.95	1.02	0.55	13.78	13.03	2.76	2.76	SL04 5015 PP	51
SEF.345.5010.13	13.58	1.97	0.94	0.51	15.75	14.53	2.17	2.36/1.57	SL04 5010 PP	53
SEF.345.5018.15	13.58	3.54	1.10	0.59	15.75	14.69	2.95	2.13	SL04 5018 PP	66
SEF.345.5014.9,5	13.58	4.72	0.71	0.37	15.75	14.29	1.97	2.13	SL04 5024 PP	48
SEF.390.5011.15	15.35	2.17	1.10	0.59	17.72	16.46	2.36	2.76/1.81	SL04 5011 PP	106
SEF.390.5016.11	15.35	3.15	0.79	0.43	17.72	16.14	2.36	2.36	SL04 5016 PP	68
SEF.390.5020.17	15.35	3.94	1.26	0.67	17.72	16.61	2.95	3.35	SL04 5020 PP	84
SEF.430.5012.16	16.93	2.36	1.18	0.63	19.69	18.11	2.76	3.14/1.81	SL04 5012 PP	97
SEF.430.5018.12	16.93	3.54	0.87	0.47	19.69	17.80	2.76	2.64	SL04 5018 PP	98
SEF.430.5024.19,5	16.93	4.72	1.42	0.77	19.69	18.35	2.95	4.13	SL04 5024 PP	169
SEF.480.5014.18	18.90	2.76	1.34	0.71	21.65	20.24	2.76	3.14/2.12	SL04 5014 PP	121
SEF.480.5024.21,5	18.90	4.72	1.57	0.85	21.65	20.47	3.15	4.13	SL04 5024 PP	209
SEF.520.5016.19	20.47	3.15	1.42	0.75	23.62	21.89	3.35	4.13/2.36	SL04 5016 PP	176
SEF.560.5020.20,5	22.05	3.94	1.54	0.81	26.18	23.58	3.94	4.33	SL04 5020 PP	242
SEF.630.5024.21,5	24.80	4.72	1.57	0.85	27.95	26.38	3.35	4.33/3.14	SL04 5024 PP	275
SEF.710.5030.23,5	27.95	5.91	1.73	0.93	31.89	29.69	3.86	3.94	SL04 5030 PP	289
SEF.710.5030.22,5	27.95	5.91	1.65	0.89	31.89	29.61	3.86	3.94	SL04 5030 PP	418
SEF.800.5032.23,5	31.50	6.30	1.73	0.93	36.22	33.23	3.94	4.29	SL04 5032 PP	473
SEF.920.5032.25,5	36.22	6.30	1.89	1.00	40.55	38.11	5.12	5.91	SL04 5032 PP	836
SEF.1020.5036.27,5	40.16	7.09	2.05	1.08	45.67	42.20	5.51	6.30	SL04 5036 PP	1188

- Different shaft sizes possible.
- Groove may be adjusted to other wire rope diameters.



SEE OUR WARNING & SAFETY INFORMATION ON PAGES 136 - 149



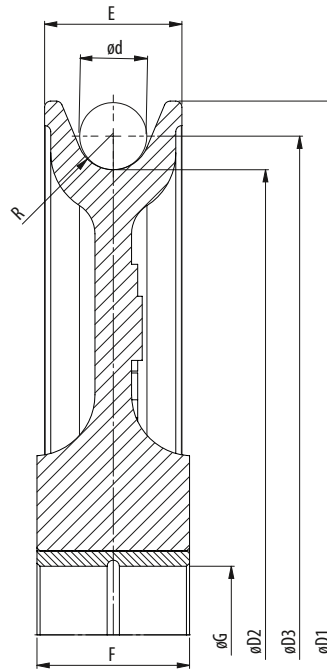

Model No.	Dimensions (inch)								Bearing	Weight (lbs)
	Sheave tread ø	Shaft ø	For wire ød	Groove radius	Outer ø	P.C.D.	Rim width	Bearing width		
	øD2	øG	d	R	øD1	øD3	E	F		
SEF.80.15.20.4,5	3.15	0.59	0.31	0.18	3.94	3.46	0.71	0.79	Bronze	1
SEF.105.22.27.5,5	4.13	0.87	0.39	0.22	4.92	4.53	0.91	1.06	Bronze	3
SEF.120.30.40.6,5	4.72	1.18	0.47	0.26	5.91	5.20	1.42	1.57	Bronze	7
SEF.165.30.40.7,5	6.50	1.18	0.55	0.30	7.87	7.05	1.42	1.57	Bronze	10
SEF.195.60.60.12	7.68	2.36	0.87	0.47	9.84	8.54	1.97	2.36	Bronze	26
SEF.210.35.45.9,5	8.27	1.38	0.71	0.37	9.84	8.98	1.57	1.77	Bronze	18
SEF.240.80.62.15	9.45	3.15	1.10	0.59	11.81	10.55	2.28	2.44	Bronze	26
SEF.250.50.60.8,5	9.84	1.97	0.63	0.33	11.81	10.47	1.77	2.36	Bronze	31
SEF.250.70.60.13	9.84	2.76	0.94	0.51	11.81	10.79	2.17	2.36	Bronze	33
SEF.255.40.50.11	10.04	1.57	0.79	0.43	11.81	10.83	1.77	1.97	Bronze	26
SEF.300.80.62.17	11.81	3.15	1.26	0.67	14.37	13.07	2.28	2.44	Bronze	33
SEF.300.80.62.15	11.81	3.15	1.10	0.59	14.37	12.91	2.28	2.44	Bronze	35
SEF.305.45.50.12	12.01	1.77	0.87	0.47	13.78	12.87	1.77	1.97	Bronze	37
SEF.305.50.50.12	12.01	1.97	0.87	0.47	13.78	12.87	1.77	1.97	Bronze	31
SEF.305.70.75.14	12.01	2.76	1.02	0.55	13.78	13.03	2.76	2.95	Bronze	44
SEF.345.50.65.13	13.58	1.97	0.94	0.51	15.75	14.53	2.17	2.56	Bronze	52
SEF.345.50.60.13	13.58	1.97	0.94	0.51	15.75	14.53	2.17	2.36	Bronze	53
SEF.345.55.65.13	13.58	2.17	0.94	0.51	15.75	14.53	2.17	2.56	Bronze	52
SEF.345.60.60.13	13.58	2.36	0.94	0.51	15.75	14.53	2.17	2.36	Bronze	50
SEF.345.60.70.16	13.58	2.36	1.18	0.63	15.75	14.76	2.17	2.76	Bronze	50
SEF.345.60.70.15	13.58	2.36	1.10	0.59	15.75	14.69	2.17	2.76	Bronze	51
SEF.345.70.70.16	13.58	2.76	1.18	0.63	15.75	14.76	2.17	2.76	Bronze	49



- Different shaft sizes possible.
- Groove may be adjusted to other wire rope diameters.

 SEE OUR WARNING & SAFETY INFORMATION ON PAGES 136 - 149



Model No.	Dimensions (inch)								Bearing	Weight (lbs)
	Sheave tread ø	Shaft ø	For wire ød	Groove radius	Outer ø	P.C.D.	Rim width	Bearing width		
	øD2	øG	d	R	øD1	øD3	E	F		
SEF.345.70.70.15	13.58	2.76	1.10	0.59	15.75	14.69	2.17	2.76	Bronze	50
SEF.345.80.80.19	13.58	3.15	1.42	0.75	15.75	15.00	2.76	3.15	Bronze	67
SEF.345.80.80.17	13.58	3.15	1.26	0.67	15.75	14.84	2.76	3.15	Bronze	68
SEF.345.80.80.15	13.58	3.15	1.10	0.59	15.75	14.69	2.95	3.15	Bronze	70
SEF.390.55.70.15	15.35	2.17	1.10	0.59	17.72	16.46	2.36	2.76	Bronze	79
SEF.390.60.70.16	15.35	2.36	1.10	0.63	17.72	16.46	2.36	2.76	Bronze	70
SEF.390.70.70.16	15.35	2.76	1.18	0.63	17.72	16.54	2.36	2.76	Bronze	69
SEF.390.70.70.15	15.35	2.76	1.10	0.59	17.72	16.46	2.36	2.76	Bronze	70
SEF.390.80.80.20	15.35	3.15	1.50	0.79	17.72	16.85	2.76	3.15	Bronze	88
SEF.390.80.80.19	15.35	3.15	1.42	0.75	17.72	16.77	2.76	3.15	Bronze	88
SEF.390.80.80.17	15.35	3.15	1.26	0.67	17.72	16.61	2.76	3.15	Bronze	90
SEF.390.80.85.19,5	15.35	3.15	1.46	0.77	17.72	16.81	2.95	3.35	Bronze	92
SEF.390.80.85.17	15.35	3.15	1.26	0.67	17.72	16.61	2.95	3.35	Bronze	106
SEF.390.90.85.19,5	15.35	3.54	1.46	0.77	17.72	16.81	2.95	3.35	Bronze	89
SEF.430.60.80.16	16.93	2.36	1.18	0.63	19.69	18.11	2.76	3.15	Bronze	97
SEF.430.80.80.20	16.93	3.15	1.50	0.79	19.49	18.43	2.76	3.15	Bronze	95
SEF.430.80.80.17	16.93	3.15	1.26	0.67	19.49	18.19	2.76	3.15	Bronze	97
SEF.430.100.80.20	16.93	3.94	1.50	0.79	19.49	18.43	2.76	3.15	Bronze	92
SEF.430.100.80.17	16.93	3.94	1.26	0.67	19.49	18.19	2.76	3.15	Bronze	95
SEF.430.100.100.19,5	16.93	3.94	1.46	0.77	19.69	18.39	3.54	3.94	Bronze	176
SEF.480.70.80.18	18.90	2.76	1.34	0.71	21.65	20.24	2.76	3.15	Bronze	115
SEF.480.120.120.21,5	18.90	4.72	1.57	0.85	21.65	20.47	3.94	4.72	Bronze	176
SEF.520.80.105.19,5	20.47	3.15	1.46	0.77	23.62	21.93	3.35	4.13	Bronze	176
SEF.520.120.90.27,5	20.47	4.72	2.05	1.08	23.43	22.52	3.15	3.54	Bronze	140
SEF.520.120.80.17	20.47	4.72	1.26	0.67	23.43	21.73	2.76	3.15	Bronze	141
SEF.520.120.90.23,5	20.47	4.72	1.73	0.93	23.43	22.20	3.15	3.54	Bronze	145
SEF.520.120.90.20	20.47	4.72	1.50	0.79	23.43	21.97	3.15	3.54	Bronze	149
SEF.560.100.110.20,5	22.05	3.94	1.54	0.81	26.18	23.58	3.94	4.33	Bronze	242
SEF.630.120.110.21,5	24.80	4.72	1.57	0.85	27.95	26.38	3.35	4.33	Bronze	252
SEF.710.150.130.23,5	27.95	5.91	1.73	0.93	31.89	29.69	3.86	5.12	Bronze	374
SEF.800.150.150.22	31.50	5.91	1.73	0.87	36.22	33.23	5.12	5.91	Bronze	594
SEF.920.160.150.22	36.22	6.30	1.61	0.87	40.55	37.83	5.12	5.91	Bronze	836
SEF.1020.180.160.24,5	40.16	7.09	1.81	0.96	45.67	41.97	5.51	6.30	Bronze	1188

- Different shaft sizes possible.
- Groove may be adjusted to other wire rope diameters.



SEE OUR WARNING & SAFETY INFORMATION ON PAGES 136 - 149

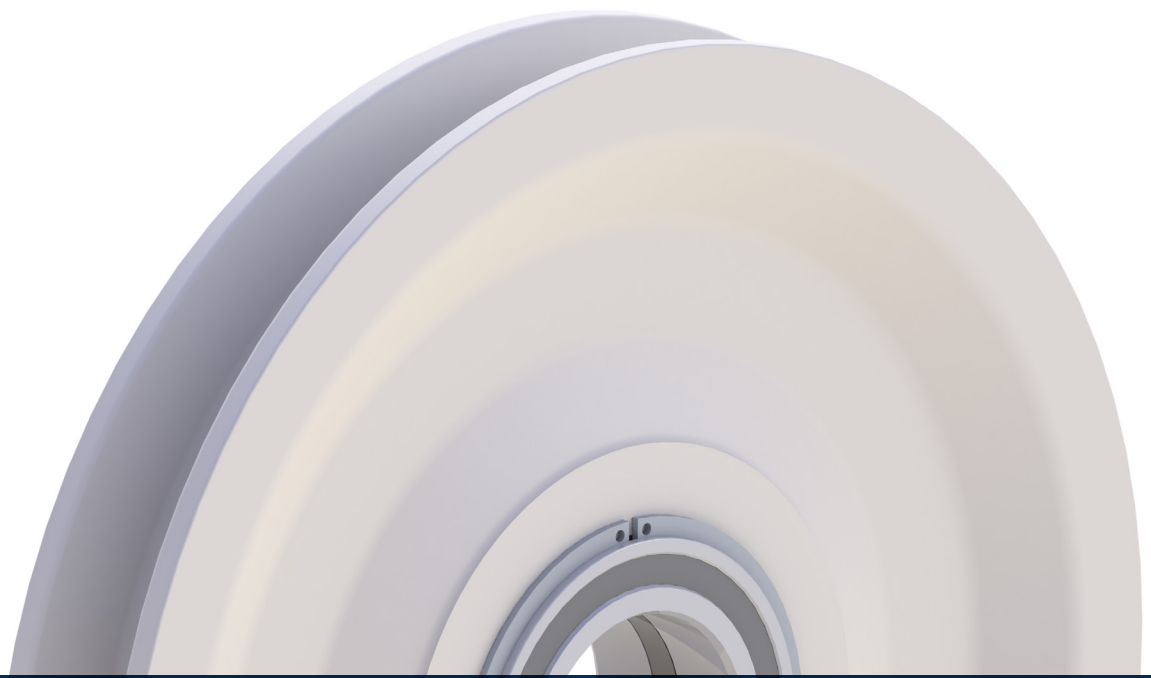

PLASTIC SHEAVES

Made fully out of Polyamid, plastic wire rope sheaves are the most lightweight sheaves in the Ropeblock portfolio. They come in many sizes, up to approx. 1000 mm (for larger diameters a hybrid solution can be considered). Plastic sheaves are cost efficient and usually available from stock.

**PLEASE NOTE THAT PLASTIC SHEAVES
ARE NOT SUITABLE FOR ALL CONDITIONS.
WE WILL BE HAPPY TO ADVISE.**



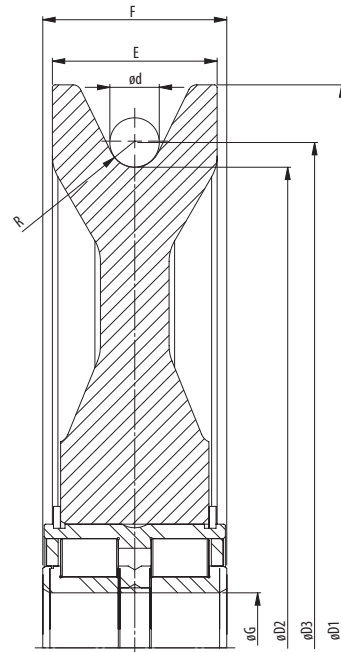
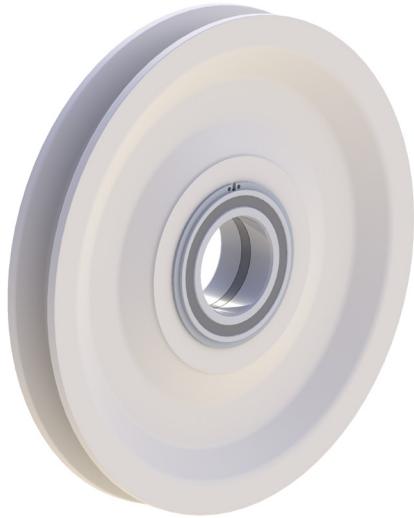

Model No.	Dimensions (inch)								Bearing	Weight (lbs)
	Sheave tread ø	Shaft ø	For wire ød	Groove radius	Outer ø	P.C.D.	Rim width	Bearing width		
	øD2	øG	d	R	øD1	øD3	E	F		
SE.260.5010.6,5.K	10.24	1.97	0.47	0.26	11.81	10.71	1.34	1.57	SL04 5010PP	6
SE.285.5012.6,5.K	11.22	2.36	0.47	0.26	12.80	11.69	1.34	1.81	SL04 5012PP	9
SE.350.5014.14.K	13.78	2.76	1.02	0.55	16.38	14.80	2.05	2.13	SL04 5014PP	13
SE.352.5013.9,5.K	13.86	2.56	0.67	0.37	15.75	14.53	1.65	1.81	SL04 5013PP	12
SE.352.5013.8,5.K	13.86	2.56	0.63	0.33	15.75	14.49	1.65	1.81	SL04 5013PP	12
SE.352.5016.8,5.K	13.86	3.15	0.63	0.33	15.75	14.49	1.97	2.36	SL04 5016PP	17
SE.400.5018.10,5.K	15.75	3.54	0.75	0.41	18.11	16.50	2.36	2.64	SL04 5018PP	22
SE.400.5018.10.K	15.75	3.54	0.71	0.39	18.11	16.46	2.36	2.64	SL04 5018PP	24
SE.400.5024.10.K	15.75	4.72	0.71	0.39	18.11	16.46	2.83	3.15	SL04 5024PP	31
SE.400.160.10.K	15.75	6.30	0.71	0.39	18.11	16.46	2.83	3.15	SL04 160PP	30
SE.482.5018.12.K	18.98	3.54	0.87	0.47	21.97	19.84	2.44	2.64	SL04 5018PP	29
SE.482.5018.11,5.K	18.98	3.54	0.83	0.45	22.05	19.80	2.44	2.64	SL04 5018PP	31
SE.482.5024.11,5.K	18.98	4.72	0.83	0.45	22.05	19.80	2.83	3.15	SL04 5024PP	39
SE.482.160.11,5.K	18.98	6.30	0.83	0.45	22.05	19.80	2.83	3.15	SL04 160PP	38
SE.528.5018.14.K	20.79	3.54	1.02	0.55	23.46	21.81	2.44	2.64	SL04 5018PP	33
SE.528.5018.12.K	20.79	3.54	0.87	0.47	23.46	21.65	2.36	2.64	SL04 5018PP	33
SE.528.5018.13.K	20.79	3.54	0.94	0.51	23.46	21.73	2.44	2.64	SL04 5018PP	33
SE.528.5018.8,5.K	20.79	3.54	0.63	0.33	23.46	21.42	2.44	2.64	SL04 5018PP	34
SE.528.5024.13.K	20.79	4.72	0.94	0.51	23.46	21.73	2.83	3.15	SL04 5024PP	46
SE.528.160.13.K	20.79	4.72	0.94	0.51	23.46	21.73	2.83	3.15	SL04 160PP	49
SE.630.160.15,5.K	24.80	6.30	1.10	0.61	27.95	25.91	2.95	3.15	SL04 160PP	62
SE.662.5026.15,5.K	26.06	5.12	1.10	0.61	29.21	27.17	3.15	3.74	SL04 5026PP	76
SE.772.5026.15,5.K	30.39	5.12	1.10	0.61	33.54	31.50	3.15	3.74	SL04 5026PP	101

- The dimensions in this table are indicative only. A drawing will always be submitted prior to production and will be the leading document when discussing dimensions.
- Sheaves shown here are standard models; inquiries for custom versions are welcome.

 SEE OUR WARNING & SAFETY INFORMATION ON PAGES 136 - 149





WELDED SHEAVES

Ropeblock welded steel sheaves are available in a range of standard models. However, it's in more customized solutions that this type of sheave really comes into its own.

Examples include applications with unusual axle sizes and/or extremely large diameters, where timing is also a key factor.

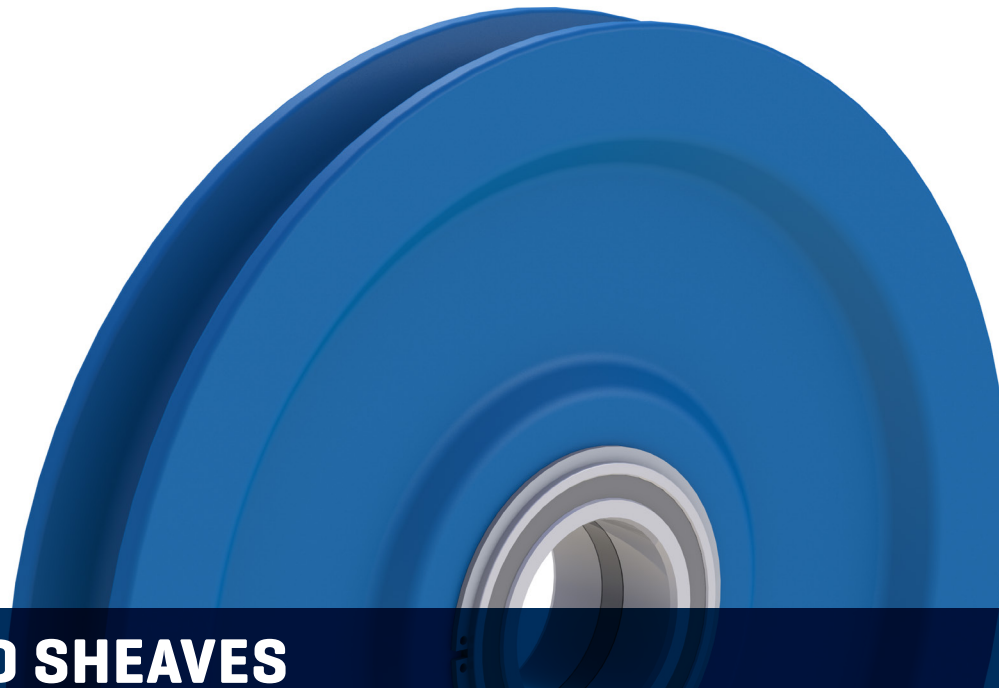

SOLID SHEAVES

Ropeblock sheaves from solid materials make for quick solutions. As we manufacture these sheaves in a simple yet highly efficient process, we can supply them quickly and in many different sizes.

Solid steel wire rope sheaves, especially, offer plenty of room for customization in terms of sizes, materials and bearing systems.



FORGED SHEAVES

Although the material properties of forged sheaves can be very similar to those of other materials, this type of sheave can be a very adequate choice for specific applications.

AVAILABLE FINISHES (DEPENDS ON THE APPLICATION)

Segment / application	ISO 12944 classification	Classification description	Expected protection duration	DFT (µm)
Construction	C2M	Slightly polluted atmosphere, predominately agriculture areas	5 to 15 year	120
Construction	C3M	Industrial and residential air pollution levels, with an average sulfur dioxide (IV) contamination level. Coastal areas with low salt content in air	2 to 5 year	120
Construction	C3M	Industrial and residential air pollution levels, with an average sulfur dioxide (IV) contamination level. Coastal areas with low salt content in air	5 to 15 year	160
Cargo handling	C3M	Industrial and residential air pollution levels, with an average sulfur dioxide (IV) contamination level. Coastal areas with low salt content in air	5 to 15 year	160
Cargo handling	C4H	Industrial areas and coastal areas with average salt content in air	more than 15 year	280
Cargo handling	C5-MM	Coastal areas and open sea with high salt content in air	5 to 15 year	280
Offshore	C4H	Industrial areas and coastal areas with average salt content in air	more than 15 year	300
Offshore	C5-MM	Coastal areas and open sea with high salt content in air	5 to 15 year	300
Offshore	C5-MH	Coastal areas and open sea with high salt content in air	more than 15 year	320
Offshore	NORSOK sys. 1*	Open sea with high salt content in air	more than 15 year	300



SEE OUR WARNING & SAFETY INFORMATION ON PAGES 136 - 149





Licensed under
API Spec 8C-0305

API SHEAVES

IMPROVED EFFICIENCY, DURABILITY AND SAFETY

Based on abundant experience with sheaves in various blocks and applications, Ropeblock developed API sheaves.

Besides the presented list for our standard sheaves, custom-made sheaves are often an optimum solution, since line pull, fleet angles and other specifications may vary.

The sheaves are weldless designed with smooth transitions and manufactured, machined and material treated with greatest care.

Characteristics include:

- Standard sheave diameter range from 26" to 82"
- Standard wire sizes 9/16" to 3"
- Meets API 8C specifications
- Unrivalled weight / fatigue performance ratio
- Groove hardness minimum 35 HRC
- Balanced
- Tapered rolling bearings, size selected to fit the application
- Other bearing types available on request
- Finish in accordance with C5-MM, C5-MH (ISO 12944) or NORSOK system 1
- Custom designs possible

Sheave Outside ø	Sheave Outside ø (mm)	Wire size range ø (inch)	Wire size range ø (mm)	Shaft ø (inch)	Shaft ø (mm)
24"	609,6	5/16 - 1	14 - 25	4 1/4	107,95
30"	762,0	1 - 1 1/8	25 - 29	5 5/8	142,88
36"	914,4	1 - 1 3/8	25 - 35	6 1/2	165,10
42"	1066,8	1 1/8 - 1 1/2	29 - 38	8	203,20
50"	1270,0	1 1/4 - 1 1/2	32 - 38	8	203,20
52"	1320,8	1 3/8 - 1 1/2	35 - 38	8	203,20
55"	1397,0	1 3/8 - 1 3/4	35 - 44	9 1/4	234,95
60"	1524,0	1 1/2 - 2 1/8	35 - 54	10 1/2	266,70
68"	1727,2	1 1/2 - 2 1/8	38 - 54	10 1/2	304,8
72"	1828,8	1 3/4 - 2 1/8	44 - 54	14	355,60
78"	1981,2	1 3/4 - 3	44 - 76	14	355,60
82"	2082,8	1 3/4 - 3	44 - 76	14	355,60

SEE OUR WARNING AND SAFETY INFORMATION ON PAGE 136



SEE OUR WARNING & SAFETY INFORMATION ON PAGES 136 - 149

GROOVE RADIUS GAUGES

STAINLESS STEEL

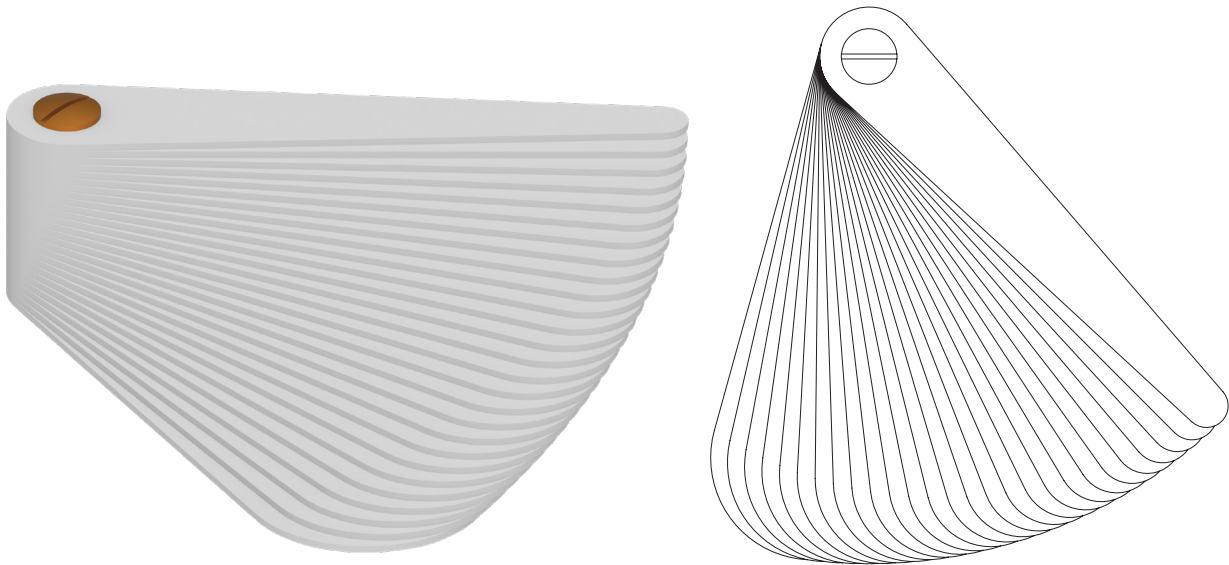

Model nr.	R-min (inch)	R-max (inch)	Steps (inch)
T G.3,5-16,5	0.14	0.65	0.02
T G.17-30	0.67	1.18	0.02
T G.4-25	0.16	0.98	0.02
T G.26-52	1.02	2.05	*
T G.30-40	1.18	1.57	0.02
T G.40-50	1.57	1.97	0.02

- Groove radius gauges enable the measuring of the radius in grooves of wire rope sheaves.
- Gauges only provide an indication of the radius of the groove and is not a calibrated measuring instrument.

* The steps differ in this model.

 SEE OUR WARNING & SAFETY INFORMATION ON PAGES 136 - 149

