

VERTICAL DIRECTIONAL BLOCKS

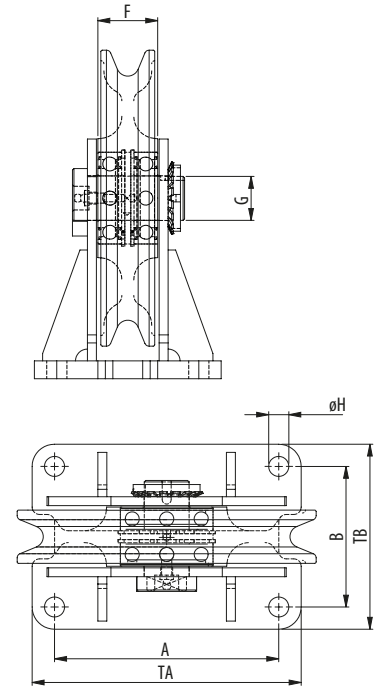
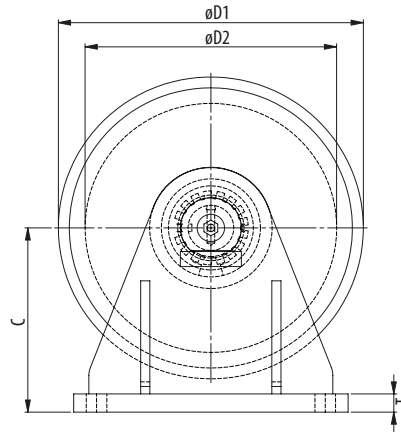
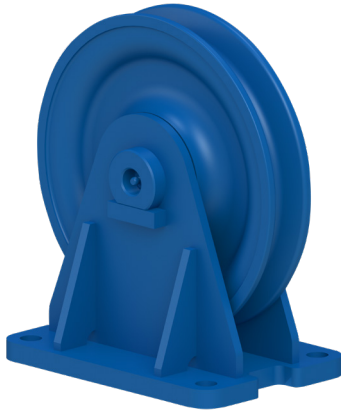

BRONZE BUSHING

Model No.	WLL (UStons)	for wire ϕd (inch)	Bearing	Dimensions (inch)										Weight (lbs)	
				$\phi D1$	$\phi D2$	A	B	C	F	G	ϕH	T	TA		TB
VLS 105.10.1.1-BR	1.1	$\frac{3}{8}$	Bronze	4.92	4.13	3.54	2.76	3.27	1.06	0.87	0.35	0.31	4.53	3.74	3
VLS 120.12.1.2-BR	2.2	$\frac{1}{2}$	Bronze	5.91	4.72	4.53	3.35	3.74	1.57	1.18	0.43	0.39	5.51	4.33	5
VLS 165.14.1.3-BR	3.3	$\frac{5}{16}$	Bronze	7.87	6.50	5.91	3.74	4.80	1.57	1.18	0.53	0.47	7.09	4.92	8
VLS 210.18.1.4-BR	4.4	$\frac{11}{16}$	Bronze	9.84	8.27	7.48	4.72	6.10	1.77	1.38	0.69	0.59	9.06	6.30	17
VLS 255.20.1.6-BR	6.6	$\frac{13}{16}$	Bronze	11.81	10.04	8.66	5.91	7.28	1.97	1.57	0.87	0.79	10.63	7.87	26
VLS 305.22.1.8-BR	8.8	$\frac{7}{8}$	Bronze	13.78	12.01	10.63	6.30	8.66	1.97	1.77	1.02	0.98	12.99	8.66	41
VLS 345.24.1.10-BR	11.0	$\frac{15}{16}$	Bronze	15.75	13.58	11.81	7.48	10.04	2.36	1.97	1.26	1.18	14.57	10.24	64

Minimum Ultimate Strength = 4 x WLL

BALL OR CYLINDRICAL ROLLER BEARING

Model No.	WLL (UStons)	for wire ϕd (inch)	Bearing	Dimensions (inch)										Weight (lbs)	
				$\phi D1$	$\phi D2$	A	B	C	F	G	ϕH	T	TA		TB
VLS 105.10.1.1	1.1	$\frac{3}{8}$	2 x Ball	4.92	4.13	3.54	2.76	3.27	1.06	0.87	0.35	0.31	4.53	3.74	7
VLS 120.12.1.2	2.2	$\frac{1}{2}$	2 x Ball	5.91	4.72	4.53	3.35	3.74	1.57	1.18	0.43	0.39	5.51	4.33	11
VLS 165.14.1.3	3.3	$\frac{5}{16}$	2 x Ball	7.87	6.50	5.91	3.74	4.80	1.57	1.18	0.53	0.47	7.09	4.92	18
VLS 210.18.1.4	4.4	$\frac{11}{16}$	Straight	9.84	8.27	7.48	4.72	6.10	1.77	1.38	0.69	0.59	9.06	6.30	37
VLS 255.20.1.6	6.6	$\frac{13}{16}$	Straight	11.81	10.04	8.66	5.91	7.28	1.97	1.57	0.87	0.79	10.63	7.87	57
VLS 305.22.1.8	8.8	$\frac{7}{8}$	Straight	13.78	12.01	10.63	6.30	8.66	1.97	1.77	1.02	0.98	12.99	8.66	90
VLS 345.24.1.10	11.0	$\frac{15}{16}$	Straight	15.75	13.58	11.81	7.48	10.04	2.36	1.97	1.26	1.18	14.57	10.24	141

Minimum Ultimate Strength = 4 x WLL

WLL= Working Load Limit on head fitting.

- The indicated WLL is valid at 180° wrap. The FoS may decrease in other loading conditions.

 SEE OUR WARNING & SAFETY INFORMATION ON PAGES 136 - 149

