

CONSTRUCTION BLOCK WITH SHACKLE

6 SHEAVE

MISCELLANEOUS BLOCKS

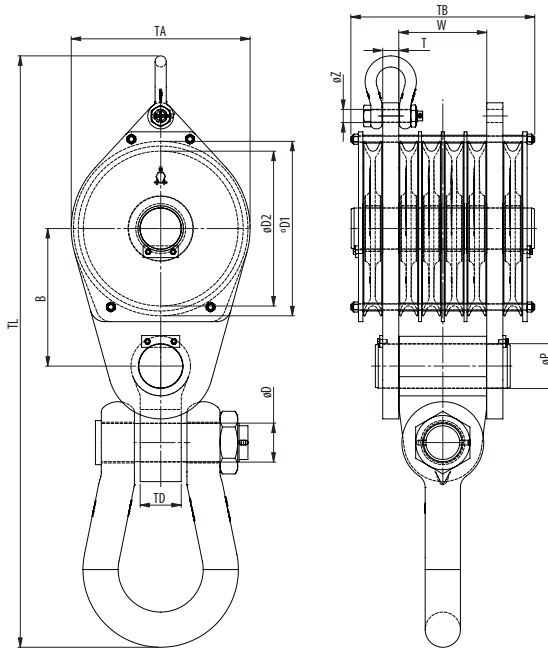
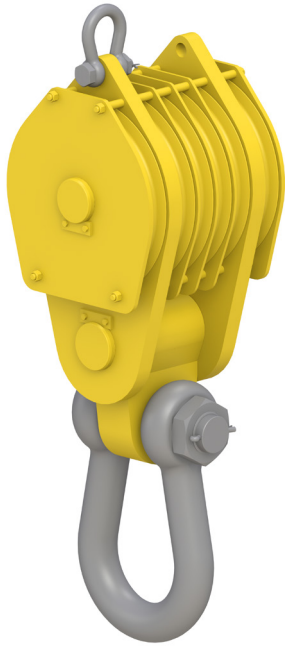

Model No.	WLL (UStons)	For wire ød (inch)	Dimensions (inch)											Weight (lbs)	
			øD1	øD2	B	øD	øP	TD	øZ	T	TA	TB	TL		W
CB 260.xx.6.55	60	1/2 - 5/8	11.8	10.2	10.7	2.9	3.1	3.1	1.1	1.2	12.2	16.7	43.6	7.8	481
CB 320.xx.6.82	90	5/8 - 3/4	14.4	12.6	12.5	3.4	3.9	4.3	1.2	1.4	14.8	17.1	51.7	7.8	758
CB 355.xx.6.110	121	3/4 - 7/8	16.1	14.0	14.1	3.9	5.1	4.7	1.6	1.8	16.5	21.7	62.3	10.5	1215
CB 400.xx.6.132	146	3/4 - 1	18.1	15.7	15.3	3.9	5.1	4.7	1.6	1.8	18.5	22.0	64.7	10.5	1472
CB 450.xx.6.160	176	7/8 - 1 1/8	20.3	17.7	16.9	4.4	5.9	5.5	1.8	2.2	20.9	24.7	70.4	11.8	2147
CB 528.xx.6.191	211	7/8 - 1 1/4	23.4	20.8	18.5	5.2	5.9	5.5	1.8	2.2	24.0	24.7	79.4	11.8	2792
CB 575.xx.6.220	243	1 - 1 1/16	25.6	22.6	20.2	5.2	6.7	5.5	2.1	2.4	26.4	28.5	85.0	13.9	3566
CB 630.xx.6.240	265	1 - 1 1/2	28.0	24.8	21.4	5.6	6.7	5.9	2.1	2.4	28.7	28.5	90.0	13.9	3837

Minimum Ultimate Strength = 4 x WLL

- Standard delivered with bronze bearing
- The dimensions in this table are indicative only. A drawing will always be submitted prior production and will be the leading document when discussing dimensions.
- Blocks shown here are standard models; inquiries for custom versions are welcome.
- Refer to wire rope manufacturers D/d ratio guideline.



SEE OUR WARNING & SAFETY INFORMATION ON PAGES 136 - 149

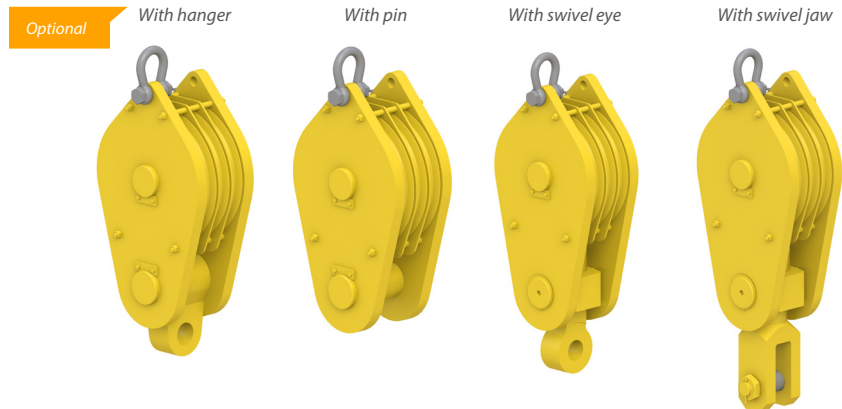

SEE OUR WARNING AND SAFETY INFORMATION ON PAGE 136

