

CONSTRUCTION BLOCK WITH SHACKLE

2 SHEAVE

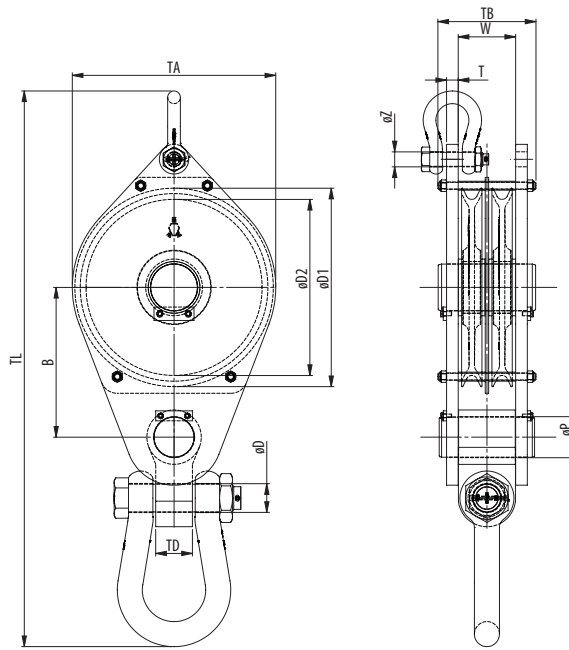

Model No.	WLL (UStons)	For wire ød (inch)	Dimensions (inch)											Weight (lbs)	
			øD1	øD2	B	øD	øP	TD	øZ	T	TA	TB	TL		W
CB 260.xx.2.27,5	30	½ - ⅝	11.8	10.2	10.1	2.1	2.4	1.8	1.1	0.8	12.2	7.5	37.3	4.2	194
CB 320.xx.2.41	45	⅝ - ¾	14.4	12.6	11.7	2.4	2.8	2.4	1.2	1.0	14.8	8.4	42.4	4.7	315
CB 355.xx.2.55	60	¾ - 7/8	16.1	14.0	13.4	2.9	3.9	3.1	1.6	1.2	16.5	9.9	52.3	5.8	520
CB 400.xx.2.68	75	¾ - 1	18.1	15.7	14.5	2.9	3.9	3.1	1.6	1.2	18.5	10.2	54.7	5.8	628
CB 450.xx.2.82	90	7/8 - 1 1/8	20.3	17.7	16.1	3.4	4.7	4.3	1.8	1.4	20.9	11.6	62.4	6.8	940
CB 528.xx.2.100	110	7/8 - 1 1/4	23.4	20.8	17.7	3.4	4.7	4.3	1.8	1.4	24.0	11.6	65.6	6.8	1130
CB 575.xx.2.114	126	1 - 1 1/16	25.6	22.6	19.4	3.9	5.5	4.7	2.1	1.6	26.4	13.3	75.9	7.8	1645
CB 630.xx.2.127	140	1 - 1 1/2	28.0	24.8	20.6	3.9	5.5	4.7	2.1	1.6	28.7	13.3	78.3	7.8	1739

Minimum Ultimate Strength = 4 x WLL

- Standard delivered with bronze bearing
- The dimensions in this table are indicative only. A drawing will always be submitted prior production and will be the leading document when discussing dimensions.
- Blocks shown here are standard models; inquiries for custom versions are welcome.
- Refer to wire rope manufacturers D/d ratio guideline.



SEE OUR WARNING & SAFETY INFORMATION ON PAGES 136 - 149

