

CONSTRUCTION BLOCK WITH SHACKLE

1 SHEAVE

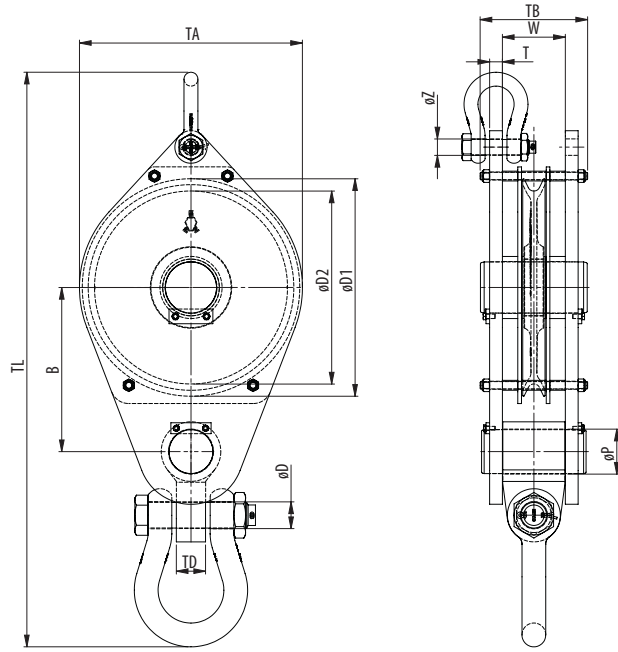
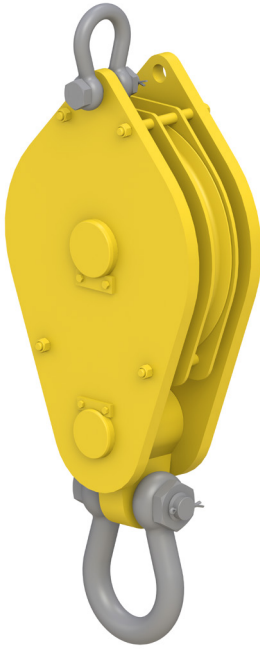

Model No.	WLL (UStons)	For wire ød (inch)	Dimensions (inch)												Weight (lbs)
			øD1	øD2	B	øD	øP	TD	øZ	T	TA	TB	TL	W	
CB 260.xx.1.18,5	20	½ - ⅝	11.8	10.2	10.1	1.8	2.4	1.4	1.1	0.8	12.2	7.5	35.3	4.2	165
CB 320.xx.1.27,5	30	⅝ - ¾	14.4	12.6	11.7	2.1	2.8	1.8	1.2	1.0	14.8	8.4	41.2	4.7	279
CB 355.xx.1.36,5	40	¾ - ⅞	16.1	14.0	13.4	2.4	3.9	2.4	1.6	1.2	16.5	9.9	48.3	5.8	452
CB 400.xx.1.45	50	¾ - 1	18.1	15.7	14.5	2.7	3.9	2.6	1.6	1.2	18.5	10.2	52.5	5.8	568
CB 450.xx.1.55	60	⅞ - 1⅛	20.3	17.7	16.1	2.9	4.7	3.1	1.8	1.4	20.9	11.6	58.7	6.8	835
CB 528.xx.1.64	70	⅞ - 1¼	23.4	20.8	17.7	2.9	4.7	3.1	1.8	1.4	24.0	11.6	61.9	6.8	1009
CB 575.xx.1.73	80	1 - 1⅞	25.6	22.6	19.4	3.4	5.5	4.3	2.1	1.6	26.4	13.3	71.2	7.8	1436
CB 630.xx.1.82	90	1 - 1½	28.0	24.8	20.6	3.4	5.5	4.3	2.1	1.6	28.7	13.3	73.6	7.8	1563

Minimum Ultimate Strength = 4 x WLL

- Standard delivered with bronze bearing
- The dimensions in this table are indicative only. A drawing will always be submitted prior production and will be the leading document when discussing dimensions.
- Blocks shown here are standard models; inquiries for custom versions are welcome.
- Refer to wire rope manufacturers D/d ratio guideline.



SEE OUR WARNING & SAFETY INFORMATION ON PAGES 136 - 149

Optional

With hanger

With pin

With swivel eye

With swivel jaw

