

SUPER REEVE CONNECTOR SOCKET WITH BOLT AND NUT

QUENCHED AND TEMPERED CAST STEEL

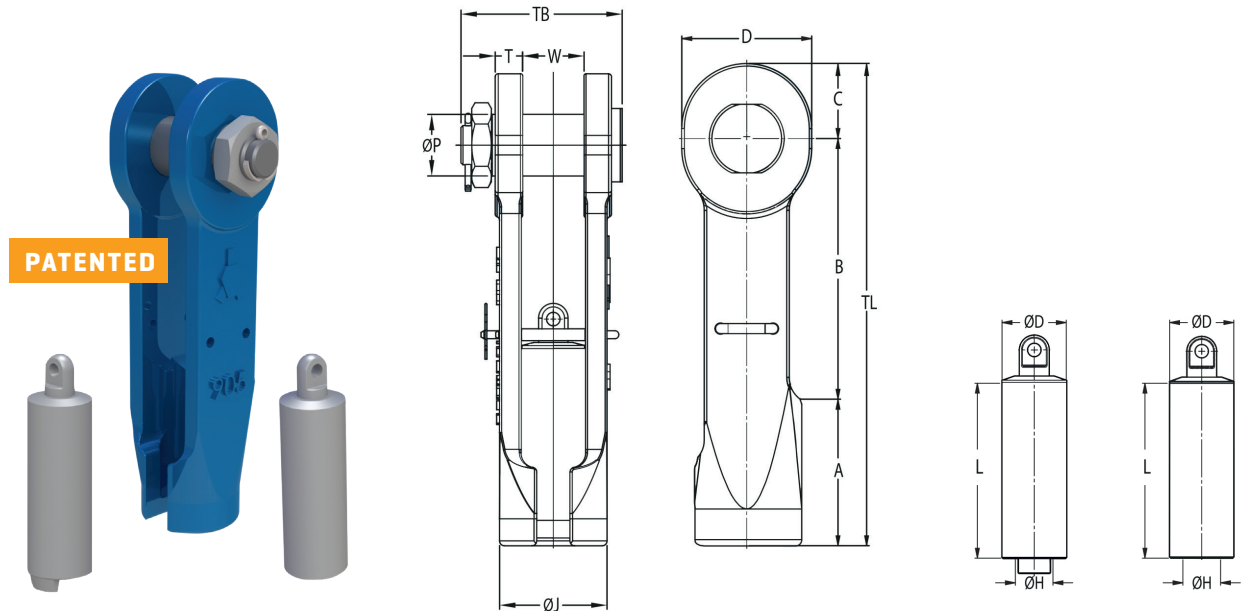

Model No.	MBL (UStons)	for wire ø		Dimensions (inch)													Weight (lbs)
		(mm)	(inch)	A	B	C	øH	øP	T	W	D	øD	øJ	L	TB	TL	
SCS 901 B	22	11-13	7/16 - 1/2	-	-	-	-	-	-	-	-	-	-	-	-	-	-
SCS 902 B	28	13-16	1/2 - 5/8	3.35	5.24	1.26	0.75	1.18	0.55	1.26	2.28	1.26	2.20	3.86	3.78	9.84	7
SCS 903 B	44	16-19	5/8 - 3/4	3.54	6.30	1.57	0.87	1.38	0.63	1.50	2.76	1.57	2.56	4.49	4.21	11.42	11
SCS 904 B	61	20-22	7/8	4.21	7.24	1.77	1.00	1.61	0.75	1.73	3.15	1.73	3.03	5.12	4.84	13.23	17
SCS 905 B	83	23-26	1	4.53	8.31	2.36	1.20	1.97	0.87	2.01	4.09	2.05	3.46	5.59	5.43	15.20	26
SCS 906 B	99	27-29	1 1/8	5.51	8.46	2.56	1.34	2.24	0.98	2.24	4.49	2.28	3.78	6.26	6.30	16.54	35
SCS 907 B	138	30-32	1 1/4	5.91	10.24	2.87	1.43	2.48	1.10	2.48	4.96	2.52	4.33	6.97	6.50	19.02	51
SCS 908 B	138	33-36	1 3/8	6.69	10.24	2.87	1.56	2.52	1.10	2.72	4.96	2.68	4.49	7.76	7.28	19.80	55
SCS 902 B.SR	28	13-16	1/2 - 5/8	3.35	5.24	1.26	0.75	1.18	0.55	1.26	2.28	1.26	2.20	3.86	3.78	9.84	7
SCS 903 B.SR	44	16-19	5/8 - 3/4	3.54	6.30	1.57	0.87	1.38	0.63	1.50	2.76	1.57	2.56	4.49	4.21	11.42	11
SCS 904 B.SR	61	20-22	7/8	4.21	7.24	1.77	1.00	1.61	0.75	1.73	3.15	1.73	3.03	5.12	4.84	13.23	17
SCS 905 B.SR	83	23-26	1	4.53	8.31	2.36	1.20	1.97	0.87	2.01	4.09	2.05	3.46	5.59	5.43	15.20	26
SCS 906 B.SR	99	27-29	1 1/8	5.51	8.46	2.56	1.34	2.24	0.98	2.24	4.49	2.28	3.78	6.26	6.30	16.54	35
SCS 907 B.SR	138	30-32	1 1/4	5.91	10.24	2.87	1.43	2.48	1.10	2.48	4.96	2.52	4.33	6.97	6.50	19.02	51
SCS 908 B.SR	138	33-36	1 3/8	6.69	10.24	2.87	1.56	2.52	1.10	2.72	4.96	2.68	4.49	7.76	7.28	19.80	55
SCS 909 B.SR	165	37-39	1 1/2	-	-	-	-	-	-	-	-	-	-	-	-	-	-
SCS 910 B.SR	187	40-42	1 5/8	-	-	-	-	-	-	-	-	-	-	-	-	-	-
SCS 911 B.SR	248	43-48	1 3/4 - 1 7/8	-	-	-	-	-	-	-	-	-	-	-	-	-	-
SCS 912 B.SR	309	49-54	2 - 2 1/8	8.86	14.69	4.25	2.36	3.74	1.77	3.98	7.64	4.13	7.28	11.02	10.35	27.80	205

MBL = Minimum Breaking Load

- The standard finish of our sockets is blue. Hot dipped galvanized is also available.
- All sockets are provided with an EN 10204-2.1 declaration of conformity, EN 10204-3.1 material certificate and can be provided with a 2006/42/EC declaration where applicable.
- Dimensional tolerances depend on the manufacturing techniques applied and are different between machined components (pins) and cast components (socket bodies and wedges).
- Also surface finish e.g. hot dip galvanizing or even paint may add to the overall thickness and fork distance.
- Please contact Ropeblock for further guidance and a detailed dimensional tolerance sheet.

