

OPEN WEDGE SOCKETS WITH BOLT AND NUT

QUENCHED AND TEMPERED CAST STEEL

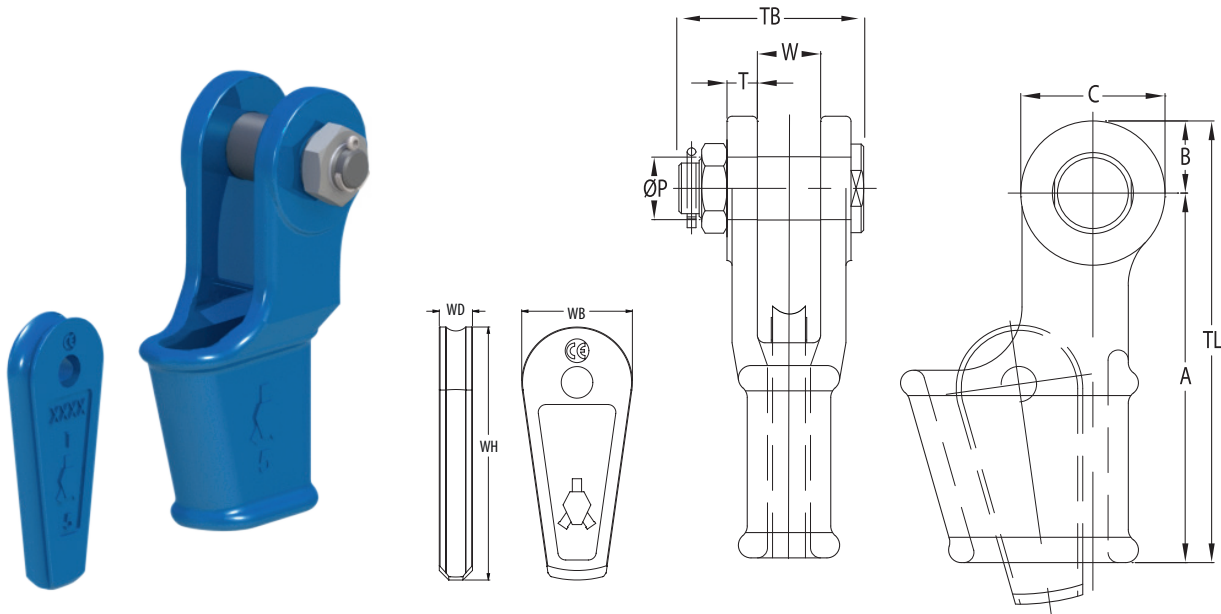

Model No.	MBL (UStons)	for wire ø		Dimensions (inch)											Weight (lbs)
		(mm)	(inch)	A	B	C	øP	T	TL	TB	W	WH	WB	WD	
OWS 0.25 B	9	7-8	5/16	4.33	0.71	1.42	0.63	0.35	5.04	2.44	0.71	2.74	1.38	0.33	2
OWS 0.5 B	13	9-10	3/8	5.71	0.91	1.81	0.81	0.43	6.61	2.95	0.81	2.91	1.42	0.47	4
OWS 1 B	22	11-13	1/2	5.75	1.12	2.24	0.98	0.47	6.87	3.15	0.98	4.53	1.89	0.55	5
OWS 2 B	28	14-16	5/8	6.93	1.38	2.76	1.18	0.59	8.31	3.78	1.22	5.30	2.24	0.71	9
OWS 3 B	44	18-19	3/4	8.27	1.57	3.15	1.38	0.63	9.84	4.21	1.50	6.30	2.76	0.83	15
OWS 4 B	61	20-22	7/8	9.35	1.87	3.74	1.61	0.71	11.22	4.84	1.73	7.34	3.03	0.94	22
OWS 5 B	83	23-26	1	10.83	2.17	4.33	2.01	0.87	12.99	5.43	2.01	8.33	3.27	1.08	33
OWS 6 B	99	27-29	1 1/8	12.20	2.56	5.12	2.24	0.98	14.76	6.30	2.24	9.11	3.58	1.18	46
OWS 7 B	121	30-32	1 1/4	13.78	2.87	5.75	2.48	1.10	16.65	6.50	2.48	10.47	4.25	1.30	68
OWS 8 B	138	34-36	1 3/8	15.75	2.91	5.83	2.52	1.10	18.66	7.28	2.76	11.73	4.57	1.38	82
OWS 9 B	165	37-39	1 1/2	17.72	3.15	5.59	2.76	1.18	20.87	7.91	3.03	13.31	5.12	1.50	112
OWS 10 B	187	40-42	1 5/8	19.69	3.43	6.30	2.99	1.30	23.11	8.23	2.99	14.67	5.51	1.61	141
OWS 11 B	248	43-48	1 3/4 - 1	21.65	3.94	7.32	3.50	1.54	25.59	9.33	3.50	16.06	5.75	1.89	212
OWS 12 B	309	49-52	2	25.20	4.13	8.07	3.74	1.81	29.33	10.35	3.98	17.72	6.30	2.09	287
OWS 13 B	397	54-58	2 1/4	25.98	4.92	9.84	4.25	2.13	30.91	11.73	4.49	18.50	6.61	2.28	397
OWS 14 B	468	60-68	2 1/2	32.87	5.31	10.63	4.76	2.36	38.19	12.99	5.00	19.69	6.93	2.56	606
OWS 15 B	507	72-76	3	39.37	5.91	11.81	5.24	2.99	45.28	14.96	5.75	21.65	9.61	2.76	970
OWS 16 B	689	81-86	3 1/4 - 3	43.31	5.91	11.81	5.51	3.11	49.21	15.63	6.26	26.38	10.24	3.15	1124

MBL = Minimum Breaking Load

- The standard finish of our sockets is blue. Hot dipped galvanized is also available.
- All sockets are provided with an EN 10204-2.1 declaration of conformity, EN 10204-3.1 material certificate and can be provided with a 2006/42/EC declaration where applicable.
- Dimensional tolerances depend on the manufacturing techniques applied and are different between machined components (pins) and cast components (socket bodies and wedges).
- Also surface finish e.g. hot dip galvanizing or even paint may add to the overall thickness and fork distance.
- Please contact Ropeblock for further guidance and a detailed dimensional tolerance sheet.

