



Construction segment

Fast Reeve Crane Blocks

Blocks shown in this section may be used on a wide variety of land based cranes such as mobile and crawler cranes. The Fast Reeve Blocks are an excellent choice for your lifting application where frequent block change is required and includes the following standard features:

- Design Factor of Safety of 4:1
- Meets performance requirements of ASME B30
- Double sealed maintenance free roller bearings
- Forged high tensile steel DIN hooks
- Ductile iron sheaves, featuring graphite lubricated groove
- High impact resistant side plates
- Operational temperature range: -40 up to +80 °C / -40 up to +176 °F
- Lubrication on hook suspension
- 4 or 8 point hook locking device
- Fast Reeve guides for fast reeving
- C3M finish in signal yellow with black striping
- Safety latch with locking pin
- Includes test report & hook certificate

Please contact your sales representative for more details

Recommended finish

Segment / application	ISO 12944 classification	Classification description	Expected protection duration	DFT (µm)
Construction	C2M	Slightly polluted atmosphere, predominately agriculture areas	5 to 15 year	120
Construction	C3M	Industrial and residential air pollution levels, with an average sulfurdioxide (IV) contamination level. Coastal areas with low salt content in air	2 to 5 year	120
Construction	C3M	Industrial and residential air pollution levels, with an average sulfurdioxide (IV) contamination level. Coastal areas with low salt content in air	5 to 15 year	160
Cargo handling	C3M	Industrial and residential air pollution levels, with an average sulfurdioxide (IV) contamination level. Coastal areas with low salt content in air	5 to 15 year	160
Cargo handling	C4H	Industrial areas and coastal areas with average salt content in air	more than 15 year	280
Cargo handling	C5-MM	Coastal areas and open sea with high salt content in air	5 to 15 year	280
Offshore	C4H	Industrial areas and coastal areas with average salt content in air	more than 15 year	300
Offshore	C5-MM	Coastal areas and open sea with high salt content in air	5 to 15 year	300
Offshore	C5-MH	Coastal areas and open sea with high salt content in air	more than 15 year	320
Offshore	NORSOK sys. 1*	Open sea with high salt content in air	more than 15 year	300

Fast Reeve Crane Blocks

5 sheaves

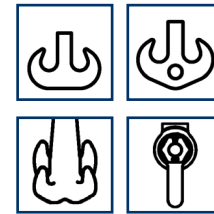
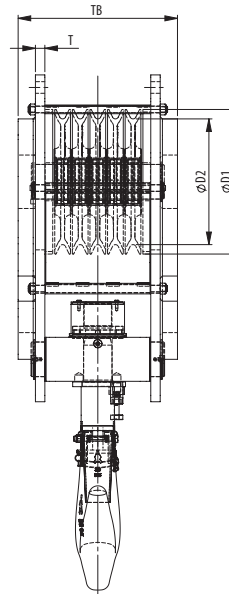
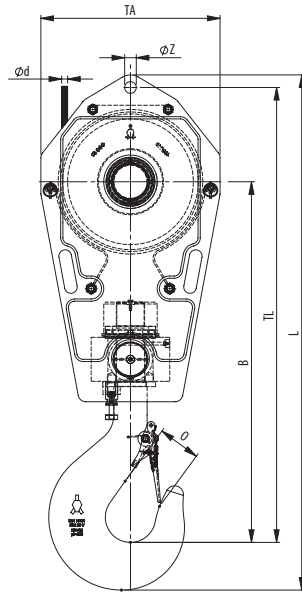

anti-rotation hook locking device



Model Nr.	WLL UStons	For wire ød inch	Hook size	Dimensions (inch)									Weight lbs
				øD1	øD2	B	O	TA	TL	L	T	øZ	
FRB 355.xx.5.55.E	60	5/16 - 7/8	12	16.1	14	37.8	3.9	19.7	48.2	52.8	TBD	TBD	1100 1280
FRB 360.xx.5.64.E	70	5/8 - 7/8	16	16.5	14.2	39.3	4.4	20.1	49.9	56.8	TBD	TBD	1340 1550
FRB 360.xx.5.70.E	77	5/8 - 7/8	16	16.5	14.2	39.3	4.4	20.1	49.9	56.8	TBD	TBD	1340 1550
FRB 360.xx.5.72.E	80	5/8 - 7/8	16	16.5	14.2	39.6	4.4	20.1	50.2	57.1	TBD	TBD	1340 1550
FRB 400.xx.5.82.E	90	5/8 - 1	20	18.1	15.7	45.2	4.9	22.4	57	62.9	TBD	TBD	1477 1540 1600 1800
FRB 400.xx.5.91.E	100	5/8 - 1	20	18.1	15.7	45.2	4.9	22.4	57	65.2	TBD	TBD	2250
FRB 450.xx.5.91.E	100	3/4 - 1 1/8	20	20.3	17.7	46.7	4.9	23.6	59.9	67.9	TBD	TBD	2250
FRB 400.xx.5.95.E	105	5/8 - 1	20	18.1	15.7	40.7	4.9	22.4	53.1	59.9	TBD	TBD	2250 2870
FRB 400.xx.5.100.E	110	5/8 - 1	20	18.1	15.7	40.7	4.9	22.4	53.1	59.9	TBD	TBD	2250
FRB 450.xx.5.100.E	110	3/4 - 1 1/8	25	20.3	17.7	49.7	5.5	23.6	62.9	69.6	TBD	TBD	1900 2200 2250 2510
FRB 528.xx.5.100.E	110	7/8 - 1 1/4	25	23.4	20.8	49.9	5.5	28	65.9	74.6	TBD	TBD	2500 2800
FRB 528.xx.5.100.E	110	7/8 - 1 1/4	25	23.4	20.8	50.9	5.5	31.1	66	75.1	TBD	TBD	2860 / 3960 / 5060*
FRB 575.xx.5.100.D	110	1 1/16 - 1 1/4	25	25.6	22.6	33.7	5.5	30.3	70.2	78.4	TBD	TBD	2860 / 3960 / 5060*
FRB 528.xx.5.119.E	130	7/8 - 1 1/4	25	23.4	20.8	52.1	5.5	27.9	67.6	76.6	TBD	TBD	3300
FRB 450.xx.5.125.D	137.5	3/4 - 1 1/8	32	20.3	17.7	50.7	6.3	23.6	63.7	72.1	TBD	TBD	3630
FRB 528.xx.5.125.E	137.5	7/8 - 1 1/4	32	23.4	20.8	52.5	6.3	28	67.8	75.3	TBD	TBD	3500 3960
FRB 450.xx.5.137.D	150	3/4 - 1 1/8	32	20.3	17.7	50.8	6.3	23.6	64.6	72	TBD	TBD	3630
FRB 528.xx.5.137.E	150	7/8 - 1 1/4	32	23.4	20.8	54.4	6.3	28	69.8	79.7	TBD	TBD	3500
FRB 670.xx.5.137.D	150	1 - 1 1/2	32	29.9	26.4	56.6	6.3	34.3	75.7	85.3	TBD	TBD	6000*
FRB 630.xx.5.150.E	165	1 - 1 3/8	32	27.9	24.8	58.8	6.3	32.7	77.9	85.4	TBD	TBD	4600 / 6100*
FRB 528.xx.5.160.E	176	7/8 - 1 1/4	40	23.4	20.8	59.1	7.1	28	77.9	86.3	TBD	TBD	4000 4500
FRB 575.xx.5.160.E	176	1 1/16 - 1 1/4	40	25.6	22.6	62.6	7.1	30.3	79.2	87.5	TBD	TBD	5500
FRB 630.xx.5.160.D	176	1 - 1 3/8	40	27.9	24.8	57.6	7.1	32.7	75.3	85.4	TBD	TBD	5500
FRB 670.xx.5.160.E	176	1 - 1 1/2	40	29.9	26.4	62.6	7.1	34.3	81.1	92	TBD	TBD	6000*
FRB 528.xx.5.182.DB	200	7/8 - 1 1/4	40	23.4	20.8	58.1	7.1	27.9	73.4	86.5	TBD	TBD	3860
FRB 575.xx.5.182.D	200	1 1/16 - 1 1/4	40	25.6	22.6	62.6	7.1	30.3	79.2	90.2	TBD	TBD	5500
FRB 630.xx.5.182.E	200	1 - 1 3/8	40	27.9	24.8	62.3	7.1	32.7	79.4	89.8	TBD	TBD	5500
FRB 670.xx.5.182.D	200	1 - 1 1/2	40	29.9	26.4	67.6	7.1	34.3	86.9	96.1	TBD	TBD	6000*
FRB 630.xx.5.200.D	220	1 - 1 3/8	50	27.9	24.8	63.9	7.9	35.4	86.1	96.8	TBD	TBD	5000 up to 15400*

NOTE xx = to be replaced by metric wire size in final part number; TBD = these dimensions vary with wire size
 * = blocks can be fitted with removable / interchangeable cheek weights

Minimum Ultimate Strength = 4 x WLL

- The dimensions in this table are indicative only. A drawing will always be submitted prior to production and will be the leading document when discussing dimensions.
- Blocks shown here are standard models; other wire rope sizes available for each model upon request.
- Refer to wire rope manufacturers D/d ratio guideline.
- Hook locking pin included on all blocks 45UStons and higher.