

D-SHACKLE WITH ROULETTE THIMBLE

TYPE D18

Material : Alloy steel, Grade R3/R3S/R4/R4S/R5
 Finish : Shackle: Painted
 Roulette thimble: Galvanized (MODU: Painted)
 Temperature range : -40°C up to +200°C, Polar Rated
 Standard certification : Certificate of Conformity
 3.1 material certificate EN 10204

Roulette thimble also separate available, see K17

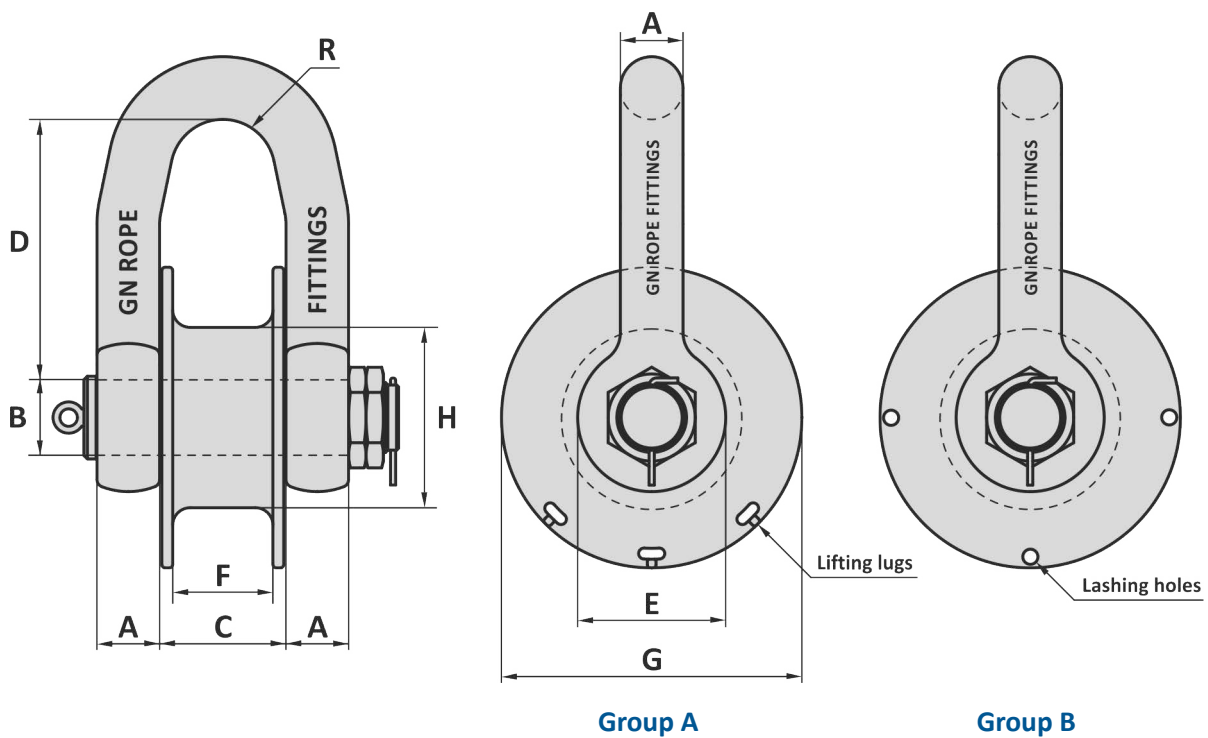

Art. No. shackle	Art. No. thimble	PL kN	MBL kN	Group	A mm	B mm	C mm	D mm	E mm	F mm	G mm	H mm	R mm	Weight kg
32110140	18010580	4886	6965	A	108	125	215	545	230	160	580	360	90	409
32150190	18010690	8478	10754		144	168	290	600	340	230	690	414	120	794
32170200	18010750	10700	13573		165	180	310	600	330	250	750	450	140	974
32180200	18010750	11889	15059		175	200	310	620	370	250	750	450	130	1107

Special MODU type shackle, suitable for 76-84 mm chain with special end link

32127145	18010144	5682	7208	B	127	145	265	600	260	205	600	390	100	553
32140159	18010610	6965	8830		140	160	270	500	305	208	610	400	100	632

Tolerance: Inside length ± 7.5%, all other forged parts ± 5%, machined parts ± 1 mm

Art. No. shackle	Art. No. thimble	PL kN	MBL kN	Group	A inch	B inch	C inch	D inch	E inch	F inch	G inch	H inch	R inch	Weight lbs
32110140	18010580	4886	6965	A	4 ¼	4 15/16	8 13/32	21 7/16	9 1/16	6 5/16	22 7/32	14 3/16	3 9/16	902
32150190	18010690	8478	10754		5 11/16	6 5/8	11 13/32	23 5/8	13 3/8	9 1/16	27 3/32	16 5/16	4 23/32	1750
32170200	18010750	10700	13573		6 ½	7 3/32	12 3/16	23 5/8	13	9 27/32	29 17/32	17 23/32	5 ½	2147
32180200	18010750	11889	15059		6 7/8	7 7/8	12 3/16	24 13/32	14 1/16	9 27/32	29 17/32	17 23/32	5 1/8	2441

Special MODU type shackle, suitable for 76-84 mm chain with special end link

32127145	18010144	5682	7208	B	5	5 23/32	10 7/16	23 5/8	10 ¼	8 1/16	23	15 11/32	3 15/16	1219
32140159	18010610	6965	8830		5 ½	6 3/16	10 ¾	19 11/16	12	8 3/16	24	15 ¾	3 15/16	1393

Tolerance: Inside length ± 7.5%, all other forged parts ± 5%, machined parts ± 1/32 inch

05-01-2018