

PMS / LTM FORGED SOCKET

TYPE S05

Material : Forged steel R3/R3S/R4/R4S
 Finish : Painted
 Temperature range : -40°C up to +200°C; Polar Rated
 Standard certification : Certificate of Conformity
 3.1 material certificate EN 10204

PMS / LTM forged sockets are prepared to operate in a wire-rope connection in combination with a flange-mounted bending stiffener. The stiffener protects the rope for buckling during transport and installation.

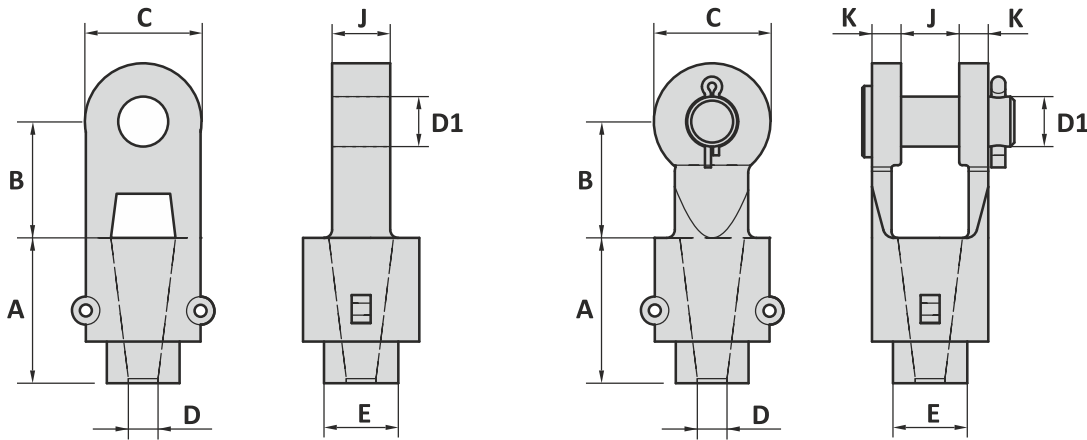

Dimensions on customer request

- Available with: Tapped holes (for lifting)
 Orkot isolation
 Padeyes
 Anode
 Bend stiffner
 Domed nuts
 Locking system

Tolerance: Machined parts ± 1 mm

GN ROPE FITTINGS

North American Stocking Distributor

8125 Saran Dr. • Playa del Rey, CA 90293

Phone: 310.448.5444 • Fax: 310.448.5446

sales@awrrinc.com

www.AssociatedWireRope.com

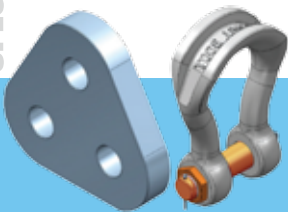

PMS / LTM FORGED SOCKET

TYPE S05



GENERAL

SHACKLES

THIMBLES

SOCKETS

LINKS

SWIVELS

HOOKS

MOORING

SPECIALS

GN ROPE FITTINGS

North American Stocking Distributor

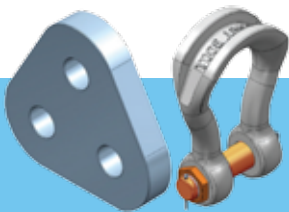

8125 Saran Dr. • Playa del Rey, CA 90293

Phone: 310.448.5444 • Fax: 310.448.5446

sales@awrrinc.com

www.AssociatedWireRope.com

