

# DOUBLE PIN / SNOTTER SHACKLE

## TYPE H12

Material : Body: High tensile steel  
Pin: Alloy steel quenched and tempered

Finish : Painted

Temperature range : -4°F up to +392°F

Standard certification : Certificate of Conformity  
3.1 material certificate EN 10204

Non-standard sizes or custom products available on request

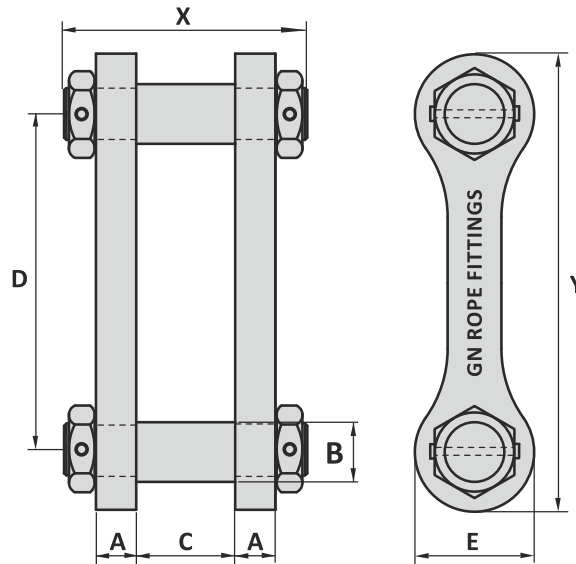
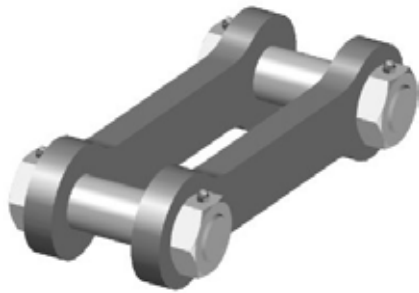

Note: Ensure that the load is centralized on the pin  
When there is too much space in the jaw gap, we advise to use washers

Art. No.	Thimble size inch	PL ton	MBL ton	A inch	B inch	C inch	D inch	E inch	X inch	Y inch	Weight lbs
38120000	12	300	500	3 <sup>3</sup> / <sub>16</sub>	4 <sup>3</sup> / <sub>16</sub>	6 <sup>1</sup> / <sub>16</sub>	21 <sup>1</sup> / <sub>4</sub>	7 <sup>15</sup> / <sub>32</sub>	20 <sup>15</sup> / <sub>32</sub>	29 <sup>17</sup> / <sub>32</sub>	465
38150000	15	300	500	3 <sup>3</sup> / <sub>16</sub>	4 <sup>3</sup> / <sub>16</sub>	7 <sup>7</sup> / <sub>8</sub>	21 <sup>1</sup> / <sub>4</sub>	7 <sup>15</sup> / <sub>32</sub>	21 <sup>2</sup> / <sub>32</sub>	29 <sup>17</sup> / <sub>32</sub>	476
38180000	18	300	500	3 <sup>3</sup> / <sub>16</sub>	4 <sup>3</sup> / <sub>16</sub>	8 <sup>7</sup> / <sub>8</sub>	27 <sup>15</sup> / <sub>16</sub>	7 <sup>15</sup> / <sub>32</sub>	22 <sup>5</sup> / <sub>8</sub>	36 <sup>7</sup> / <sub>32</sub>	538
38210000	21	300	500	3 <sup>3</sup> / <sub>16</sub>	4 <sup>3</sup> / <sub>16</sub>	9 <sup>27</sup> / <sub>32</sub>	27 <sup>15</sup> / <sub>16</sub>	7 <sup>15</sup> / <sub>32</sub>	23 <sup>3</sup> / <sub>8</sub>	36 <sup>7</sup> / <sub>32</sub>	551

Tolerance: Machined parts ± <sup>1</sup>/<sub>32</sub> inch

# GN ROPE FITTINGS

North American Stocking Distributor

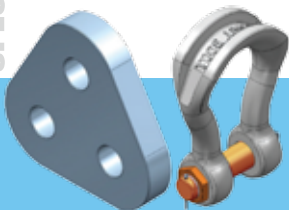

8125 Saran Dr. • Playa del Rey, CA 90293  
Phone: 310.448.5444 • Fax: 310.448.5446  
sales@awrrinc.com  
www.AssociatedWireRope.com



# DOUBLE PIN / SNOTTER SHACKLE

## TYPE H12

Material : Body: High tensile steel  
Pin: Alloy steel quenched and tempered

Finish : Painted

Temperature range : -20°C up to +200°C

Standard certification : Certificate of Conformity  
3.1 material certificate EN 10204

Non-standard sizes or custom products available on request

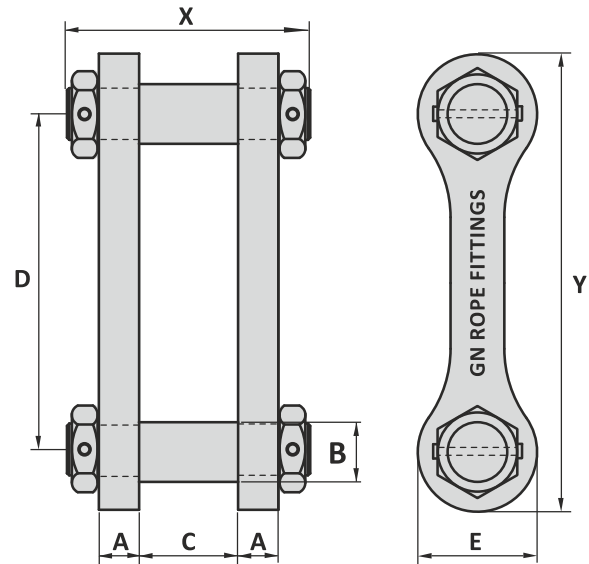
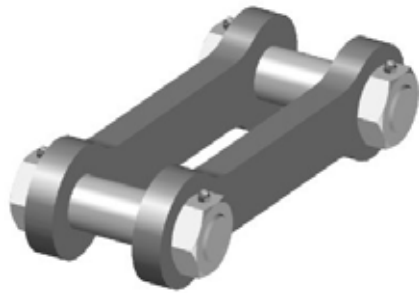

Note: Ensure that the load is centralized on the pin  
When there is too much space in the jaw gap, we advise to use washers

Art. No.	Thimble size inch	PL ton	MBL ton	A mm	B mm	C mm	D mm	E mm	X mm	Y mm	Weight kg
38120000	12	300	500	90	110	170	540	190	520	750	211
38150000	15	300	500	90	110	200	540	190	550	750	216
38180000	18	300	500	90	110	225	710	190	575	920	244
38210000	21	300	500	90	110	250	710	190	600	920	250

Tolerance: Machined parts  $\pm$  1 mm

# GN ROPE FITTINGS

North American Stocking Distributor

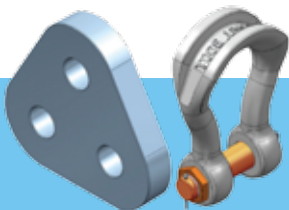

8125 Saran Dr. • Playa del Rey, CA 90293  
Phone: 310.448.5444 • Fax: 310.448.5446  
sales@awrrinc.com  
www.AssociatedWireRope.com



GENERAL

SHACKLES

THIMBLES

SOCKETS

LINKS

SWIVELS

HOOKS

MOORING

SPECIALS